

CFORCE

110

Owner's Manual

**READ THIS
MANUAL
CAREFULLY**

It contains important
safety information

Operators under 10 are prohibited.
No passengers are allowed.

TABLE OF CONTENTS

FOREWORD	1
Welcome	1
Signal Words	3
INTRODUCTION	7
Vehicle Identification Numbers and Key Information	8
TECHNICAL SPECIFICATIONS	9
OPERATOR SAFETY	11
Safety Precautions	11
Equipment Modifications	12
Safety Training	13
Potential Hazards and How To Avoid Them	16
Safe Riding Gear	36
Safety Decals & Locations	39
FEATURES & CONTROLS	42
Left Hand Controls	42
Right Hand Controls	46
Foot Brake	48
ELECTRONIC FENCE	50
About CFMOTO YOUTH App	51
Electronic Fence Operation	52

Electronic Fence Receiver - Pairing With The Vehicle	54
Electronic Fence Receiver QR Code	55
Fuel Tank.....	56
Key Switch	56
Gear Shift Lever(state No.1)	57
Gear shift pedal (state No.2)	58
Front Service Cover	59
Dashboard Indicators and Warnings	61
OPERATING YOUR VEHICLE	64
Break-In Period	64
Gear Shifting	65
Responsibility of Operators and Guardians	66
Practice Exercises.....	69
Off-Road Operation.....	75
MAINTENANCE	80
Severe Use	80
Pre-ride Maintenance Check.....	83
Break-in Periodic Maintenance Chart	84
Periodic Maintenance Schedule.....	86
Engine Oil Inspection	91
Engine Oil Change	92

Air Filter	94
Spark Arrestor	98
Braking System	99
Foot Brake Pedal Height Adjustment	104
Cable Inspection and Lubrication	104
Wheel and Tires	105
Drive Chain Inspection	107
Chain Adjustment(state No.1)	109
Chain Adjustment(state No.2)	110
Battery	111
Lights.....	114
Front and Rear Shock Absorber.....	115
Cleaning & Storage	116
Preparation for Storage.....	117
Battery Storage	119
Transporting the Vehicle.....	120
VEHICLE DIAGNOSIS.....	121
Declaration	127
Declaration of Vibration declaration.....	128
ZHEJIANG CFMOTO POWER CO., LTD.....	129

FOREWORD

Welcome

Thank you for purchasing a CFMOTO vehicle, and welcome to our world-wide family of CFMOTO enthusiasts. Be sure to visit us online at www.cfmoto.com for the latest news, new product introductions, upcoming events, and more.

CFMOTO is an international company that specializes in the development, manufacture, and marketing of all-terrain vehicles, utility vehicles, large displacement motorcycles, and their core components. Founded in 1989, CFMOTO is devoted to the development of independent brand cultivation and R&D innovation. CFMOTO products are currently distributed through more than 2000 companions worldwide in more than 100 countries and regions. CFMOTO is edging into the advanced ranks in the world of powersports, and aims to supply superior products to dealers and fans globally.

For safe and enjoyable operation of your vehicle, be sure to follow the instructions and recommendations in this owner's manual. Your manual contains instructions for minor maintenance. Information about major repairs is outlined in the CFMOTO Service Manual. Your CFMOTO dealer knows your vehicle best and is interested in your total satisfaction. Be sure to return to your dealership for all of your maintenance needs during, and after the warranty period.



This vehicle can be hazardous to operate. Before operating, drivers must meet the following basic requirements:

1. The driver's age should be 10 years or older.
2. The driver should receive driving training from a certified instructor and be proficient with vehicle driving skills.
3. Familiarize yourself with all laws, regulations and permitted driving areas before operating this vehicle.
4. Read this owner's manual. Understand all safety warnings, precautions and operating procedures before operating this vehicle.
5. This vehicle is a type of child vehicle, operation in any condition should be under the supervision of the parents / guardian.

Operation is prohibited if the driver cannot meet the requirements.

FOREWORD

Signal Words

A signal word calls attention to a safety message or messages, a property damage message or messages, and designates a degree or level of hazard seriousness. The standard signal words in this manual are DANGER, WARNING, CAUTION and NOTE or NOTICE.

The following signal words and symbols appear throughout this manual and on your vehicle. Your safety is involved when these words and symbols are used. Become familiar with their meanings before reading the manual:

DANGER

This safety alert and icon indicates a potential hazard that may result in serious injury or death.

WARNING

This safety alert and icon indicates a potential hazard that may result in minor or moderate personal injury and/or damage to the vehicle.

CAUTION

This safety alert without an icon indicates a situation that may result in damage to the vehicle.

NOTE or NOTICE

A note or notice will alert you to important information or instructions.

FOREWORD

 **WARNING FOR TYPE I ATV**

(1-person vehicle)



**ALWAYS
USE AN
APPROVED
HELMET AND
PROTECTIVE
GEAR.**



**NEVER USE
ON PUBLIC
ROADS.**



**NEVER CARRY
A PASSENGER.**

FOREWORD

NEVER:

- Operate without proper training or instruction.
- Operate on public roads. A collision can occur with another vehicle.
- Operate at speeds too fast for your skill or the conditions.
- Use ALCOHOL or DRUGS before or while driving this vehicle.

ALWAYS:

- Use proper riding techniques to avoid vehicle from overturning on hills and rough terrain and when turning.
- Wear eye protection, helmet and protective clothing.

FOREWORD
READ THE OWNER'S MANUAL.
FOLLOW ALL INSTRUCTIONS AND WARNINGS.

 WARNING

Read, understand, and follow all of the instructions and safety precautions in this manual and on all product labels. Failure to follow the safety precautions could result in serious injury or death.

Warning

All assembly work must be done by adults.

Children under 3 years old are at risk of choking, because before assembly there are many small parts. All fasteners must be fully tightened. Children are not allowed to touch accessories, such as batteries and electric parts, and to help assemble the vehicle.

INTRODUCTION

Thank you for purchasing a CFMOTO vehicle, and welcome to our world-wide family of CFMOTO enthusiasts.

For safe and enjoyable operation of your vehicle, be sure to follow the instructions and recommendations in this owner's manual. Information about major repairs are outlined in the CFMOTO Service Manual, and should only be performed by a CFMOTO service dealer and technician. Be sure to return to your dealership for all of your service needs during, and after, the warranty period.

If you have questions or concerns about your vehicle

All questions or concerns related to your vehicle should be directed to your local CFMOTO dealer first. Your dealer knows your vehicle best and is interested in your total satisfaction. In the event your local dealer is unable to resolve a product issue or concern, you can reach a CFMOTO customer service representative depending on the market you reside in:

For USA: Please contact CFMOTO POWERSPORTS, INC. TEL: 763-398-2690, by e-mail: info@cfmotousa.com, or online: <https://cfmotousa.com/customer-care/customer-care-contact>. Please note that customer service does not have authority to approve or deny warranty, and cannot provide technical repair data, diagnosis, or instructions.

For CANADA: Please contact CANADA MOTOR IMPORT INC. TEL: 1-418-227-2077, or online: <https://www.cfmoto.ca/en/customer-care/>.

For a safety concern related to your Canadian vehicle, you may report your concern to Transport Canada Defect Investigation and Recalls Division by mail, telephone, or online using the contact information below:

Mailing address: Transport Canada - ASFAD, 330 Sparks Street, Ottawa, ON, K1A 0N5.

TEL: 819-994-3328 (Ottawa-Gatineau area or international) or toll-free: 1-800-333-0510 (In Canada).

Online: <http://www.tc.gc.ca/recalls>.

INTRODUCTION

Vehicle Identification Numbers and Key Information

Record your vehicle's identification numbers in the spaces provided. This vehicle is equipped with one key switch and 2 keys, if both keys are lost, contact your authorized dealer for a new key switch.

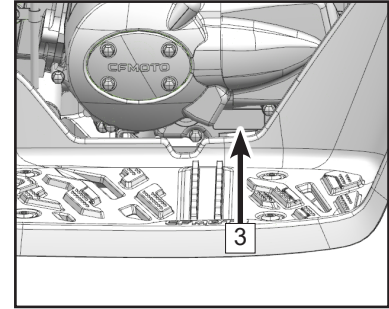
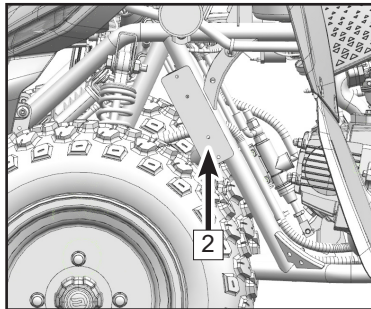
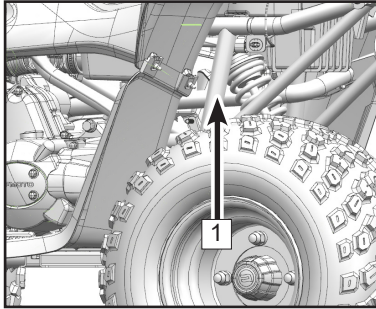

1 Vehicle Identification Number: _____

2 Vehicle Frame Number: _____

3 Engine Number: _____

TECHNICAL SPECIFICATIONS

Items	Specifications	
	CFORCE 110	
	CF110AY10	CF110AY10-2
Vehicle Type	Y10	
Overall Length	58 in. (1483 mm)	
Overall Width	37 in. (943 mm)	
Overall Height	36 in. (925 mm)	
Wheel Base	40 in. (1020 mm)	
Minimum Ground Clearance	4 in. (110 mm)	
Minimum Turning Radius	118 in. (3000 mm)	
Curb Weight	287 lb. (130 kg) (Fuel included)	271 lb. (123 kg) (Fuel included)
Vehicle Maximum Load Capacity:	155 lb. (70.5kg)	
Drive Motor Type	4-stroke Single Cylinder	
Bore x Stroke	52.4 mm x 49.5 mm	
Displacement	107 cc	
Compression Ratio	9.1:1	
Starting Type	Electric Start	
Fuel Supply System	Electronic Fuel Injection (EFI)	
Lubrication Type	Pressure / Splash lubrication	

TECHNICAL SPECIFICATIONS

Items	Specifications	
Engine Oil Type Engine Oil Replacement	SAE 15W-40 / SAE 10W-40 / SAE 5W-40 0.7 qt (660 mL)	
Air Filter	Foam Prefilter	
Fuel Fuel Type Capacity Fuel Reserve Amount At Fuel Gauge 'Flash'	95 or higher unleaded gasoline 6.76 qt (6.4 L) 2.11 qt (2 L)	Don't have Fuel Reserve Amount At Fuel Gauge 'Flash'
Suspension Front Shock Absorber Rear Shock Absorber	Oil damper, 5 position preload adjustable Oil damper, 4 position preload adjustable	
Electrical System Ignition	APP / START button	
Battery	12V 5Ah	
Light System Headlight Position Light Tail light / Brake Light	LED 28*2.43W 32*0.6W/12*3.2W	/
APP Control Position	GPS+RF	

OPERATOR SAFETY

Safety Precautions

DANGER

Failure to heed the warnings contained in this manual can result in serious injury or death. This vehicle is a 'Y'-type ATV, and its operation could be hazardous. This vehicle handles differently from other vehicles, such as cars. A collision or rollover can occur quickly, even during routine maneuvers like turning or driving over obstacles, if you fail to take proper precautions.

Read this owner's manual. Understand all safety warnings, precautions, and operating procedures before operating this ATV.

Age Restrictions

CFORCE 110: CF110AY10, CF110AY10-2

Operation is prohibited for anyone under the age of 10. No passenger is allowed on this vehicle. Children differ in skills, physical abilities and judgment. Some children may not be able to operate an ATV safely. Continued use is permitted only if the parents / guardian determine that the operator has the ability and maturity to operate the ATV safely. Be sure the operator can reach and operate all ATV controls, including handlebars, brake levers, throttle lever and stop switch.

Know Your Vehicle

As the operator of the vehicle, you are responsible for your personal safety, the safety of others, and the protection of our environment. Read and understand your owner's manual, which includes valuable information about all aspects of your vehicle, including safe operating procedures.

OPERATOR SAFETY

Equipment Modifications

CFMOTO is concerned with the safety of our customers and for the general public. Therefore, we strongly recommend that consumers do not install on a vehicle, any equipment that may increase the speed or power of the vehicle, or make any other modifications to the vehicle for these purposes.

Any modifications to the original equipment of the vehicle create a substantial safety hazard and increase the risk of body injury.

If any faults and consequences occur to the vehicle as a result of consumers removing modifications by themselves, they should bear all responsibilities. And we will terminate the warranty on your vehicle immediately.

Therefore, please follow the national and local government regulations on the use of the vehicle.

 DANGER

Consumers should not make any modification to the original vehicle, and any unapproved modification may lead to serious safety hazards.

Modifications to the vehicle or electric parts may affect the riding safety, endurance and vehicle performance.

Improper installation of accessories may lead to safety hazards.
--

Always use CFMOTO original parts and approved accessories. The vehicle performance will be influenced and legal requirements may also be broken if consumers use non-CFMOTO original parts or install accessories incorrectly. Please note that you are responsible for your own safety and the safety of others.

 CAUTION
--

CFMOTO recommends consumers use only CFMOTO original parts and accessories approved that are specially designed and verified for this vehicle.
--

OPERATOR SAFETY

Safety Training

When you purchased your new ATV, your dealer offered a hands-on safety training course that covers all aspects of vehicle safety. You were also provided with printed materials that explain safe operating procedures. You should review this information on a regular basis. If you purchased a used ATV from a party other than a dealer, you can request safety training from any authorized dealer.

DANGER

Serious injury or death may occur if you do not follow the following instructions and procedures outlined in this owner's manual:

- Read this manual and all decals carefully, and follow the operating procedures described.
- Never operate an ATV without proper instructions. Take a training course. Beginners should receive training from a certified instructor. Contact an authorized dealer nearest you to find out about the training courses.
- Never permit a guest to operate the ATV unless the guest has read this manual, all product labels, and has completed a certified safety training course.
- Never operate an ATV without wearing an approved helmet that fits properly. Always wear eye protection (goggles or face shield), gloves, boots, a long-sleeved shirt or jacket, and long pants.
- Never consume alcohol or drugs before or while operating an ATV.
- Never operate an ATV at excessive speeds. Travel at speeds appropriate for the terrain, visibility and operating conditions, and your experience.
- Never try wheelies, jumps or other stunts.
- Always inspect your ATV before each-time use to make sure it's in safe operating condition.
- Always follow the inspection and maintenance procedures and schedules outlined in owner's manual.

OPERATOR SAFETY

- Always keep both hands on the handlebars and both feet on the footrest of the ATV during operation.
- Always travel slowly and use extra caution when operating on unfamiliar terrains. Be alert to terrain conditions.
- Never operate on excessively rough, slippery, or loose terrains.
- Always follow proper turning procedures as described in this manual. Practice turnings at low speeds before attempting to turn at faster speeds. Do not turn at excessive speeds.
- Always have the ATV inspected by an authorized dealer if it's been involved in an accident.
- Never operate on hills too steep for the ATV or for your abilities. Practice on smaller hills before attempting larger hills.
- Always follow proper procedures for climbing hills. Check the terrain carefully before ascending a hill.
- Never go over the top of a hill at high speeds.
- Always follow proper procedures for going downhill and for braking on hills. Check the terrain carefully before you start down a hill. Shift your weight backward. Never go down a hill at high speeds. Avoid going down a hill at an angle, which would cause the vehicle to lean sharply to one side. Travel straight down the hill when possible.
- Always follow proper procedures for crossing the side of a hill. Avoid hills with excessively slippery or loose surfaces. Shift your weight to the uphill side of the ATV. Never attempt to turn the ATV around on any hill until you've mastered (on level ground) the turning technique outlined in this manual. Avoid crossing the side of a steep hill when possible.
- Always use proper procedures if you stall or reverse while climbing a hill. To avoid stalling, maintain a steady speed when climbing a hill. If you stall or roll backwards, follow the special procedure for braking described in this manual. Always dismount on the uphill side, or to either side if the ATV is pointed straight uphill. Turn the ATV around and remount by following the procedure described in

OPERATOR SAFETY

this manual.

- Always check for obstacles before operating in a new area. Never attempt to operate over large obstacles, such as rocks or fallen trees. Always follow proper procedures when operating over obstacles as described in this manual.
- Always be careful of skidding or sliding. On slippery surfaces like icy roads, travel slowly and use extra caution to reduce the risk of skidding or sliding out of control.
- Avoid operating the ATV through deep or fast-flowing water. This vehicle is prohibited to cross any watery area.
- Wet brakes may have reduced stopping ability. Test your brakes after leaving water. If necessary, apply them lightly several times while driving slowly to allow friction to dry out the pads.
- Always check for obstacles or people behind the ATV before operating in reverse gear. When it's safe to reverse, move slowly and avoid turning at sharp angles.
- Always use the size and type of tires specified for your ATV, and always maintain proper tire pressure.
- Never modify an ATV through improper installation or use of accessories.
- Always remove the ignition key when the vehicle is not in use to prevent unauthorized use or accidental starting.
- Never touch running parts, such as wheels, drive chain, etc.

FOR MORE INFORMATION ABOUT ATV SAFETY, PLEASE CONTACT YOUR DEALER.

OPERATOR SAFETY

Potential Hazards and How To Avoid Them

⚠️ WARNING

POTENTIAL HAZARD:

Operating this ATV without proper instruction.

WHAT CAN HAPPEN:

The risk of an accident is greatly increased if the operator does not know how to operate this vehicle properly in different situations and on different types of terrain.

HOW TO AVOID THE HAZARD:

Beginning and inexperienced operators should complete a certified training course offered by a dealer. Operators should regularly practice the skills learned in the course and the operating techniques described in the owner's manual.

⚠️ WARNING

POTENTIAL HAZARD:

Failure to follow the age recommendations for this ATV.

WHAT CAN HAPPEN:

Severe injury and/or death could occur if a child under the minimum age recommendation operates this vehicle. Even though a child may be within the recommended age group for operating this kind of vehicle, he/she may not have the skills, abilities or judgment needed to operate this vehicle safely and could be susceptible to accident or injury.

HOW TO AVOID THE HAZARD:

Follow the age requirement. Operation in any situation should be under the supervision and protection of parents.

OPERATOR SAFETY

⚠️ WARNING

POTENTIAL HAZARD:

Operation on paved surfaces such as sidewalks, trails parking lots, or public highways and streets.

WHAT CAN HAPPEN:

ATV tires are designed for off-road use. Driving on paved surfaces greatly affects how an ATV handles, which can result in loss of control and/or an accident.

HOW TO AVOID THE HAZARD:

Never drive on paved surfaces. If it is unavoidable, slow down and do not make sudden turning or braking maneuvers.

Never operate ATVs on public highways or streets if it is not allowed by law. Check local laws to determine if it is legal to do so.

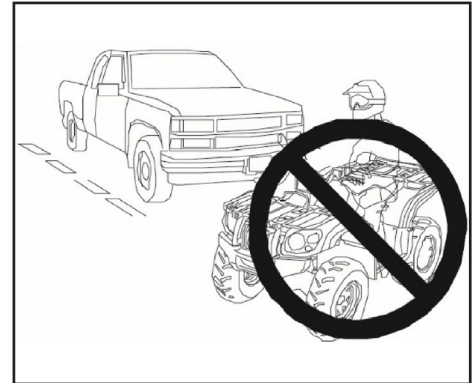
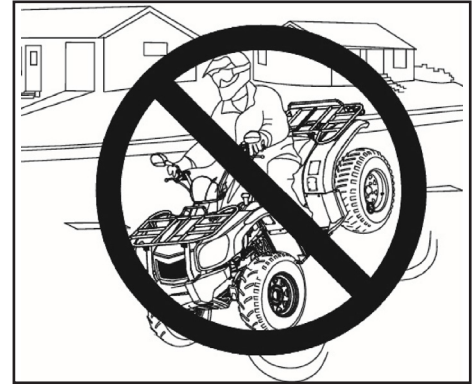

OPERATOR SAFETY

⚠️ WARNING

POTENTIAL HAZARD:

Operating this ATV without wearing an approved helmet, eye protection, and protective clothing.

WHAT CAN HAPPEN:

Operating an ATV without an approved helmet increases the risk of a severe head injury or death in the event of an accident. Operating without eye protection could result in an accident and could increase the chance of a severe eye injury in the event of an accident. Operating without protective clothing could increase the chance of a severe injury.

HOW TO AVOID THE HAZARD:

Always wear an approved helmet that fits properly. Always wear eye protection (goggles or face shield), gloves, long-sleeved shirt or jacket, and long pants.

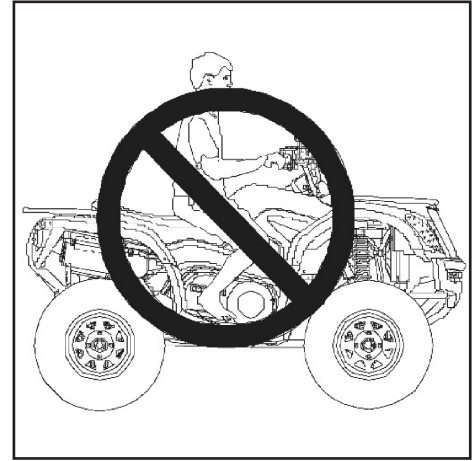

OPERATOR SAFETY

⚠️ WARNING

POTENTIAL HAZARD:

Operating the ATV after consuming alcohol or drugs.

WHAT CAN HAPPEN:

Consumption of alcohol and/or drugs could seriously affect operator's judgment. Reaction time may be slower and operator's balance and perception could be affected. Consumption of alcohol and/or drugs before or while operating an ATV could result in an accident causing severe injury or death.

HOW TO AVOID THE HAZARD:

Never consume alcohol or drugs before or while operating an ATV.



OPERATOR SAFETY

⚠️ WARNING

POTENTIAL HAZARD:

Operating the ATV at excessive speeds.

WHAT CAN HAPPEN:

Excessive speed increases the operator's chance of losing control of the ATV, which can result in an accident.

HOW TO AVOID THE HAZARD:

Always operate the ATV at a speed that's proper for the terrain, visibility and operating conditions, and your experience.

⚠️ WARNING

POTENTIAL HAZARD:

Attempting wheelies, jumps and other stunts.

WHAT CAN HAPPEN:

Attempting stunts increases the chance of an accident, including an overturn.

HOW TO AVOID THE HAZARD:

Never attempt wheelies, jumps, or other stunts. Avoid exhibition driving.

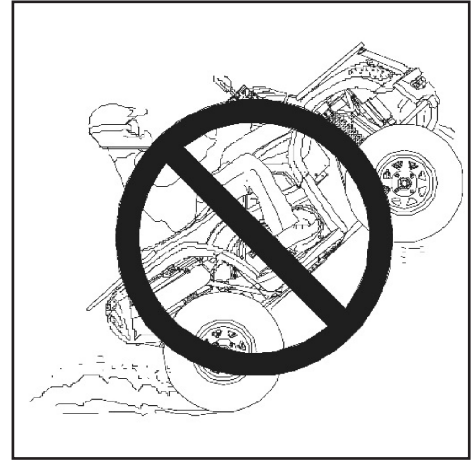

OPERATOR SAFETY

⚠WARNING

POTENTIAL HAZARD:

Failure to inspect the ATV before operating. Failure to properly maintain the ATV.

WHAT CAN HAPPEN:

Poor maintenance increases the possibility of an accident or equipment damage.

HOW TO AVOID THE HAZARD:

Always inspect your ATV before each use to make sure it's in safe operating condition.

Always follow the inspection and maintenance procedures and schedules described in the owner's manual.

⚠WARNING

POTENTIAL HAZARD:

Removing hands from the handlebars or feet from the footrests during operation.

WHAT CAN HAPPEN:

Removing even one hand or foot can reduce ability to control the vehicle or could cause loss of balance and ejection from the ATV.

If the operator's foot is not firmly planted on the footrest, it could come into contact with the rear wheels and lead to an accident or injury.

HOW TO AVOID THE HAZARD:

Always keep both hands on the handlebars and both feet on the footrests of the ATV during operation.

OPERATOR SAFETY

⚠️ WARNING

POTENTIAL HAZARD:

Failure to use extra caution when operating the ATV on unfamiliar terrain.

WHAT CAN HAPPEN:

Unfamiliar terrain may contain hidden rocks, bumps, or holes that could cause loss of control or overturn.

HOW TO AVOID THE HAZARD:

Travel slowly and use extra caution when operating on unfamiliar terrain. Always be alert to changing terrain conditions.

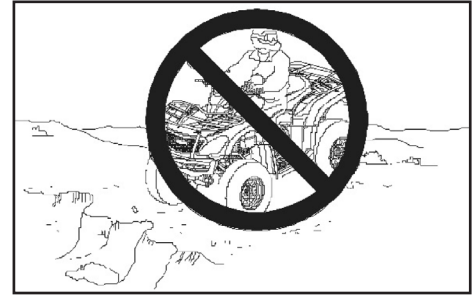

OPERATOR SAFETY

⚠️ WARNING

POTENTIAL HAZARD:

Failure to use extra caution when operating on excessively rough, slippery or loose terrain.

WHAT CAN HAPPEN:

Operating on excessively rough, slippery or loose terrain could cause loss of traction or loss of control, which could result in an accident or overturn.

HOW TO AVOID THE HAZARD:

Do not operate on excessively rough, slippery or loose terrain until you've learned and practiced the skills necessary to control the ATV on such terrain. Always use extra caution on rough, slippery or loose terrain.



OPERATOR SAFETY

⚠️ WARNING

POTENTIAL HAZARD:

Turning improperly.

WHAT CAN HAPPEN:

Improper turns could cause loss of control and lead to a collision or overturn.

HOW TO AVOID THE HAZARD:

Always follow proper procedures for turning as described in the owner's manual. Practice turning at slow speeds before attempting to turn at faster speeds. Never turn at excessive speed.

OPERATOR SAFETY

⚠️ WARNING

POTENTIAL HAZARD:

Climbing excessively steep hills or climbing hills improperly.

WHAT CAN HAPPEN:

Improper hill climbing could cause loss of control or overturn.

HOW TO AVOID THE HAZARD:

Never operate on hills too steep for the ATV or for your abilities. Practice on smaller hills before attempting large hills. Always check the terrain carefully before ascending any hill. Never climb hills with excessively slippery or loose surfaces. Shift your weight forward. Never open the throttle suddenly while traveling uphill. The ATV could flip over backwards. Never go over the top of any hill at high speed. An obstacle, a sharp drop, or another vehicle or person could be on the other side of the hill.

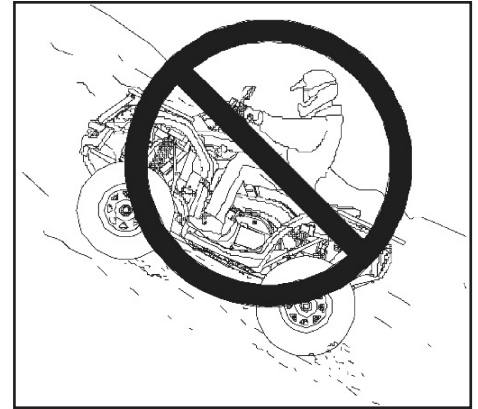

OPERATOR SAFETY

⚠️ WARNING

POTENTIAL HAZARD:

Traveling down excessively steep hills.

WHAT CAN HAPPEN:

Improper downhill travel could cause loss of control or overturn.

HOW TO AVOID THE HAZARD:

Never operate on hills too steep for the ATV or for your abilities. Practice on smaller hills before attempting large hills. Always check the terrain carefully before attempting any hill. Never descend hills with excessively slippery or loose surfaces.

NOTE

A special driving and braking technique is required while traveling downhill. Always check the terrain carefully before descending a hill. Shift your weight backward. Never travel down a hill at high speed. Avoid traveling down a hill at an angle, which would cause the vehicle to lean sharply to one side. Travel straight down the hill when possible.



OPERATOR SAFETY

⚠️ WARNING

POTENTIAL HAZARD:

Improperly crossing hills and turning on hills.

WHAT CAN HAPPEN:

Improperly crossing or turning on hills could cause loss of control or overturn.

HOW TO AVOID THE HAZARD:

Never attempt to turn the ATV around on any hill until you've mastered the turning technique on level ground as described in the owner's manual.

Use extra caution when turning on any hill. Avoid crossing the side of a steep hill.

WHEN CROSSING THE SIDE OF A HILL:

Always follow proper procedures as described in the owner's manual. Avoid hills with excessively slippery or loose surfaces. Shift your weight to the uphill side of the ATV.



OPERATOR SAFETY

⚠️ WARNING

POTENTIAL HAZARD:

Stalling, rolling backwards or improperly dismounting while climbing a hill.

WHAT CAN HAPPEN:

The vehicle could overturn.

HOW TO AVOID THE HAZARD:

Maintain a steady speed when climbing a hill.

IF ALL FORWARD SPEED IS LOST:

Close the throttle. Keep your weight uphill. Apply the front brake. When fully stopped, apply the foot brake as well, then shift the gear selector to the park position.

IF THE ATV BEGINS ROLLING:

Keep weight uphill. Never apply engine power. Never apply the foot brake while rolling backwards. Apply the front brake. When fully stopped, apply the foot brake and shift the gear selector to the parking position (if equipped). Dismount on uphill side, or to either side if ATV is pointed straight uphill.

Turn the ATV around and remount, following the procedure described in the owner's manual.



OPERATOR SAFETY

WARNING

POTENTIAL HAZARD:

Improperly operating over obstacles.

WHAT CAN HAPPEN:

Operating over obstacles could cause loss of control or overturn.

HOW TO AVOID THE HAZARD:

Before operating in a new area, check for obstacles. Avoid operating over large obstacles such as rocks and fallen trees when possible. If unavoidable, use extreme caution and always follow proper procedures as outlined in the owner's manual.

OPERATOR SAFETY

⚠WARNING

POTENTIAL HAZARD:

Skidding or sliding.

WHAT CAN HAPPEN:

Skidding or sliding can cause loss of control. If the tires regain traction unexpectedly, the ATV could overturn.

HOW TO AVOID THE HAZARD:

On slippery surfaces such as ice, travel slowly and use extra caution to reduce the chance of skidding or sliding out of control.

⚠WARNING

POTENTIAL HAZARD:

Overloading the ATV or carrying/towing cargo improperly.

WHAT CAN HAPPEN:

Overloading and towing can cause changes in vehicle handling, which could lead to loss of control or an accident.

HOW TO AVOID THE HAZARD:

Never exceed the stated load capacity for this ATV.

Do not carry cargo or pull a trailer. Allow a greater distance for braking if the vehicle is weighted near the load capacity.

OPERATOR SAFETY

⚠️ WARNING

POTENTIAL HAZARD:

Operation of the ATV through deep or fast-flowing water.

WHAT CAN HAPPEN:

The tires may float, causing loss of traction and loss of control, which can lead to an accident or overturn.

HOW TO AVOID THE HAZARD:

Avoid operating the ATV through deep or fast-flowing water. If it is unavoidable to enter water that exceeds the recommended maximum depth, travel slowly, balance your weight carefully, avoid sudden movements, and maintain a slow and steady forward motion. Do not make sudden turns or stops, and do not make sudden throttle changes. Wet brakes may have reduced stopping ability. Always test the brakes after leaving the water. If necessary, apply brakes several times to dry out the pads.

OPERATOR SAFETY

⚠️ WARNING

POTENTIAL HAZARD:

Improperly operating in reverse.

WHAT CAN HAPPEN:

The ATV could collide with an obstacle or person, resulting in severe injury.

HOW TO AVOID THE HAZARD:

Before shifting into reverse gear, always check for obstacles or people behind the ATV. When it's safe to proceed, back slowly.

⚠️ WARNING

POTENTIAL HAZARD:

Operating this ATV with improper tires, or with improper or uneven tire pressure.

WHAT CAN HAPPEN:

Use of improper tires, or operation of the ATV with improper or uneven tire pressure, could cause loss of control or an accident.

HOW TO AVOID THE HAZARD:

Always use the size and type of tires specified in the owner's manual for the ATV. Always maintain proper tire pressure.

OPERATOR SAFETY

⚠️ WARNING

POTENTIAL HAZARD:

Operating the ATV with improper modifications.

WHAT CAN HAPPEN:

Improper installation of accessories or modification of the ATV may cause changes in handling which could lead to an accident.

HOW TO AVOID THE HAZARD:

Never modify the ATV through improper installation or use of accessories. All parts and accessories added to the vehicle must be genuine parts or equivalent components designed for use on this ATV and should be installed and used according to approved instructions. Consult your dealer for more information.

OPERATOR SAFETY

WARNING

POTENTIAL HAZARD:

Operating on frozen bodies of water.

WHAT CAN HAPPEN:

Severe injury or death can result if the ATV and/or the operator fall through the ice.

HOW TO AVOID THE HAZARD:

Never operate the ATV on a frozen body of water.

OPERATOR SAFETY

WARNING

Before operating the vehicle, inspect the frame and handlebars for cracks or broken connection points. Aggressive operating or crashing into objects may damage or destroy the frame or handlebars.

WARNING

After any rollover or accident, have an authorized dealer inspect the entire vehicle for possible damage, including (but not limited to) brakes, throttle and steering systems.

WARNING

Do not operate the vehicle near flammable vapors (gasoline, paint thinner, acetone or liquid wax, etc.). Electrical switches may emit internal sparks that could cause an explosion or fire.

WARNING

Safe operation of this vehicle requires good judgment and physical skills. Persons with cognitive or physical disabilities who operate this vehicle have an increased risk of rollover and loss of control, which could result in severe injury or death.

OPERATOR SAFETY

Safe Riding Gear

Guardians should provide wear safe riding gear for children, including:

1. An approved helmet
2. Goggles
3. Gloves
4. Long-sleeved shirts or jackets
5. Long pants
6. Over-the-ankle boots

According to the actual weather, you may need extra apparel, such as anti-fog goggles, thermal underwear and a face guard for cold weather. The operator must never wear loose clothing that may get entangled in the vehicle or on tree branches and shrubs.

Helmets and Goggles

An approved helmet can prevent a serious head injury if an accident occurs. Please note that even the best helmet is no guarantee against injury.

The helmet you choose should meet the standard for your country or area and its size should suit you. A closed-face helmet with face shield will be better at preventing impacts from insects, flying rocks, dust and scattered debris, etc.

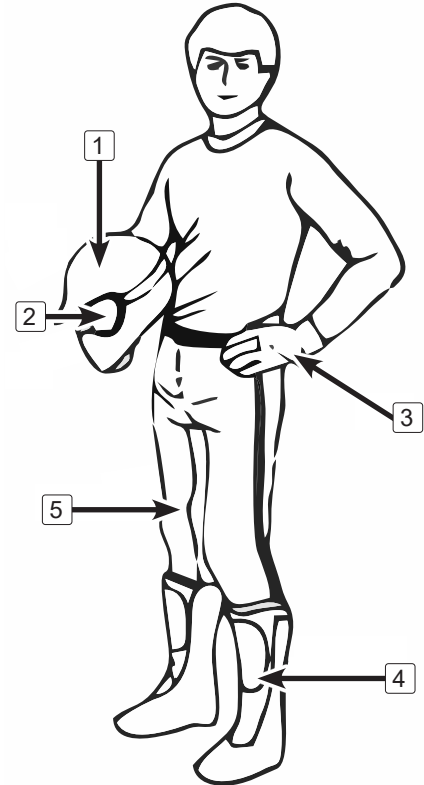

OPERATOR SAFETY

An open-face helmet can not offer the same protection for your face and jaw. Please wear detachable face masks and goggles when wearing an open-face helmet.

Do not depend on eyeglasses or sunglasses for enough eye protection, as they may fly out or shatter in case of an accident to cause second damage, and they can not prevent wind and airborne objects from getting into eyes.

Use tinted masks or goggles only during the day in bright light, do not use them at night or in poor light. They may affect your ability to distinguish colors. Do not use them if your color discrimination is affected.

Gloves

Full-finger gloves could protect your hands from wind, sun, heat, cold, and splash. Well-fitted gloves are helpful for steering and relieving hand fatigue. If the gloves are too heavy, it will be difficult to operate the vehicle.

A pair of strong motorcycle gloves offers protection for your hands in the event of an accident or turnover. Snowmobile gloves offer better protection when operating in cold areas.

OPERATOR SAFETY

Jackets, Pants and Motorcycle Suits

Wear a jacket or a long-sleeved shirt and long pants, or a full set of riding suit. Quality protective gear will provide comfort, and it can help you avoid being distracted by adverse environmental elements. In case of an accident, good quality protective gear made of sturdy material may prevent or reduce injury.

When riding in a cool weather, protect yourself against hypothermia which is a state of low body temperature and can cause loss of concentration, slowed reactions and loss of smooth, precise muscle movement. In cool conditions, proper protective gear like a windproof jacket and insulated layers of clothing are essential. Even while riding at moderate temperatures, you can feel very cold due to the wind.

Protective gear that is appropriate for cold-weather riding may be too hot when the vehicle is stopped. Dress in layers so that clothing can be removed as desired. Topping the protective gear with a windproof outer layer can prevent cold air from reaching the skin.

Boots

Always wear closed-toe, over-the-ankle boots. Sturdy over-the-ankle boots with non-slip soles offer more protection, and allow you to put your foot properly on the foot pegs. Avoid long shoelaces that could get entangled in the vehicle components. In winter, rubber-soled boots with either nylon or leather uppers and removable felt liners are best suited. Avoid rubber boots which may get trapped behind or in the foot brake pedal, impairing proper operation.

Other Riding Gear

Rain Gear

When riding in rainy weather, a rain suit or a waterproof riding suit is recommended. On long rides, it is a good idea to carry rain gear. Keeping clothes is beneficial for keeping operators being much more comfortable and alert.

Safety Decals & Locations

Warning decals have been placed on the ATV for your protection. Read and follow the instructions of each decal on the vehicle carefully. If a decal becomes illegible or comes off, contact your dealer for replacement. Warning decals in the owner's manual are for reference.

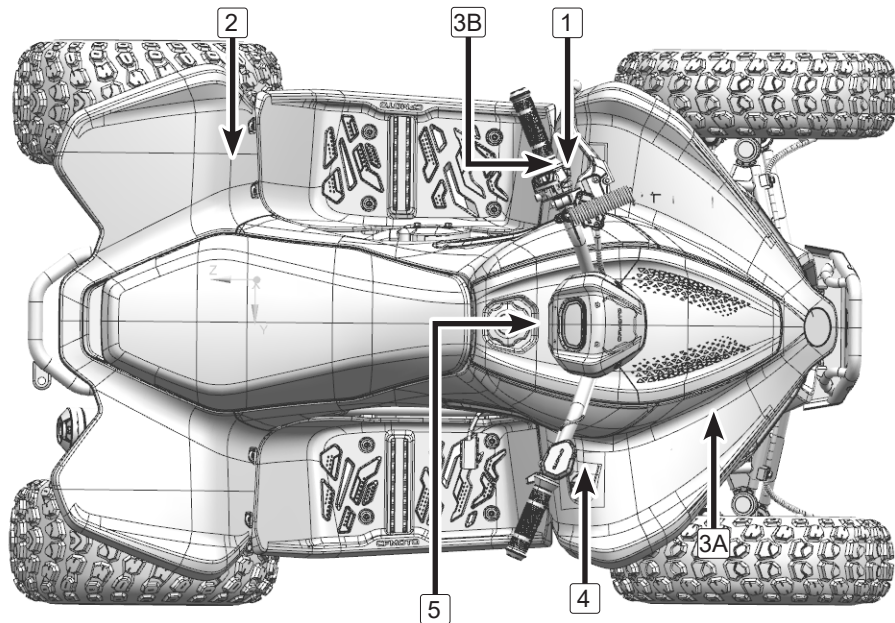

OPERATOR SAFETY

1



2

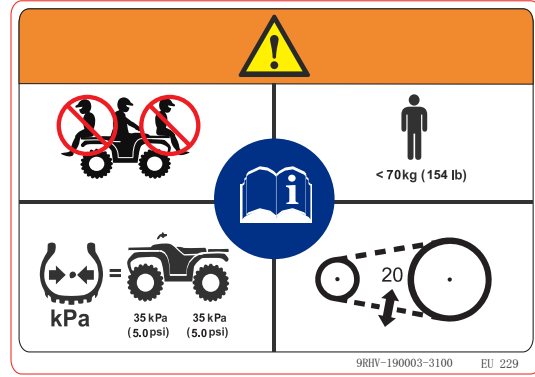

OPERATOR SAFETY

3A 3B



4

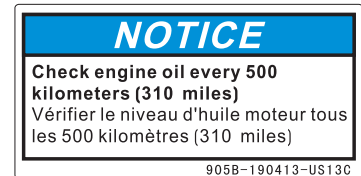

5

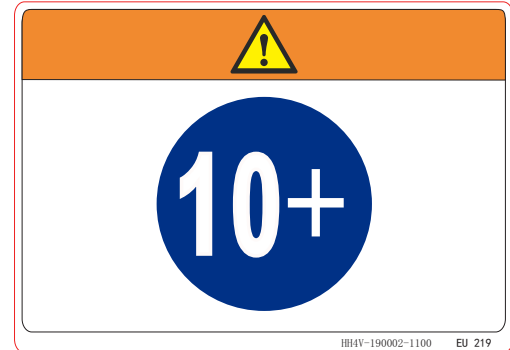

FEATURES & CONTROLS



FEATURES & CONTROLS

Left Hand Controls

1 Start switch



	Short press the button, the horn will sound.
---	--

2 Stop Switch

	When the button is released, the electrical system stops working.
	When the button is pressed, the electrical system starts working.

3 Light switch

(Available in Select Markets)

	Turn to this position, the headlight is on.
	Turn to this position, the headlight is off.

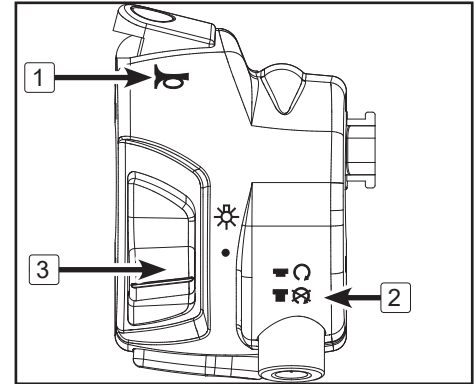

FEATURES & CONTROLS

4 Horn Button

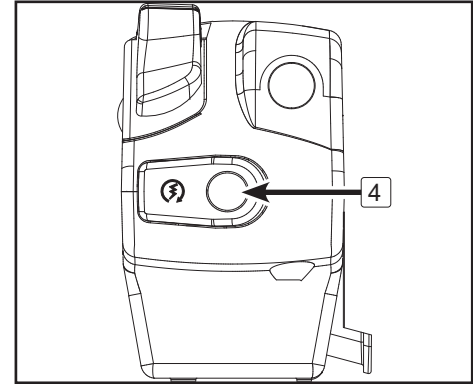
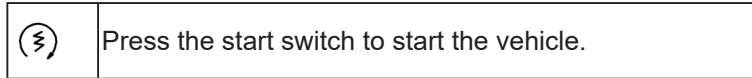

5 Safety Lock and Safety Lanyard

For the vehicle to operate, the end of the safety lanyard must be connected on the safety lock seat as shown. The other end of the safety lanyard should be connected to a part of the operator's body that is higher than the hand position.

If an accident causes the driver to fall from the vehicle, the safety lanyard will disconnect from the safety lock seat and vehicle power shuts off at once.

When powering the vehicle, verify the safety lanyard is completely fitted well on the safety lock seat. The vehicle will not operate without the safety lanyard installed.

If the safety lanyard is lost, please contact your CFMOTO dealer to purchase a new one.

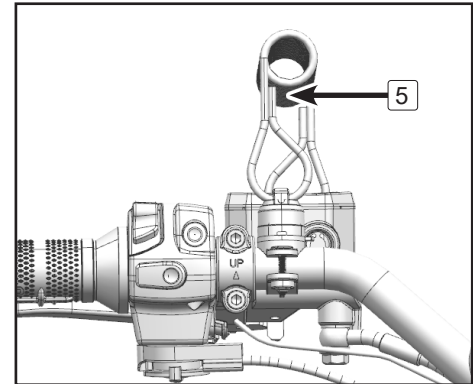

FEATURES & CONTROLS

6 Hand Brake Fluid Reservoir and Level Indicator

Check the hand brake master cylinder fluid level before each use of the ATV. The hand brake master cylinder is located on the right handlebar. The fluid level can be viewed through the indicator window on the side of the master cylinder. If the fluid level is lower than the “low” mark, refill with brake fluid as necessary.

⚠ WARNING

An over-full master cylinder may cause brake resistance or brake lock-up, which could result in serious injury or death. Maintain brake fluid at the recommended level. Do not overfill the reservoir.

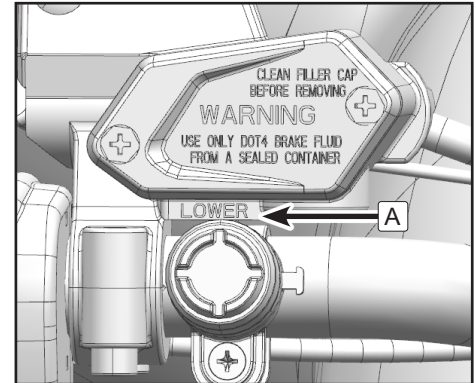
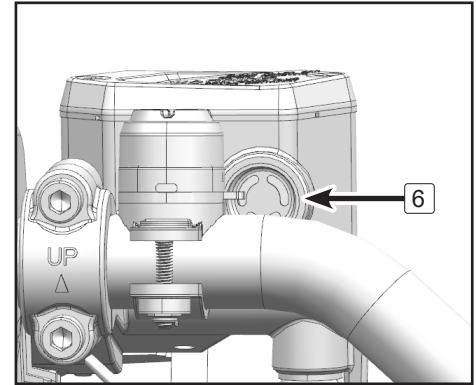

FEATURES & CONTROLS

7 Hand Brake Lever (including hydraulic parking)

The hand brake lever is located on the left handlebar and controls the front and rear brakes. Pull the lever toward the handlebar to apply the brakes. When squeezed, the lever should feel firm. Any sponginess would indicate a possible fluid leak or low master cylinder fluid level, which must be corrected before riding. Contact your dealer for proper diagnosis and repairs.

Hydraulic parking brake is located at the hand brake lever. To activate the function, squeeze the lever and step on foot brake at the same time, then use the right hand to press the hydraulic parking brake lever **A**.

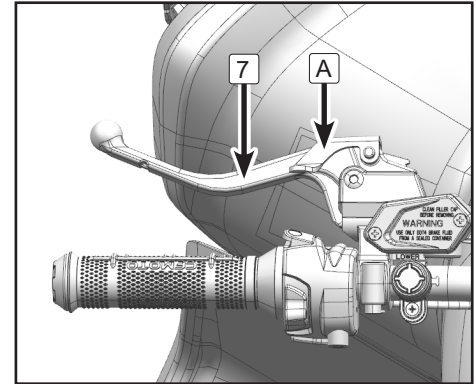

⚠ CAUTION

When parking on slopes, do not depend solely on the hydraulic parking brake. For safety, please use a large heavy object to block the wheel and prevent the vehicle from sliding or rolling.

FEATURES & CONTROLS

Right Hand Controls

1 Throttle Lever

When the motor is running, press the throttle lever to increase motor's running speed. The vehicle speed is adjusted by changing the position of throttle lever. The throttle lever is a spring-return type. If the operator's hand is removed from the throttle lever, the vehicle will slow down and the motor will return to an idle state. Before starting the vehicle, please inspect that the throttle lever's operation is smooth. Make sure it returns back to the idle position when released.

CAUTION

Before turning on the motor, please inspect that the operation of throttle lever is smooth, and if not, check for reasons. If you cannot find a problem or solution, please contact a CFMOTO dealer.

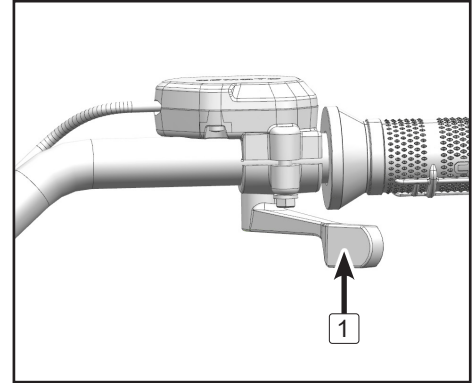

FEATURES & CONTROLS

2 Mechanical Speed Limiter

WARNING

This vehicle type is Y-10, its speed limited by the local laws.

According to ANSI®/SVIA-1-2010 (sec. 6.22), the speed is controlled within 15mph (24km/h) or below when delivery to the consumer;

To better protect the safety of teenagers, even the users require to disassemble or adjust the vehicle speed limiting setting, which is not allowed.

We recommended that the beginner screw in the speed limiting screw, with the driver's familiarity with the vehicle, to adjust the speed limiting setting properly.

We recommended that the beginner screw in the speed limiting screw, with the driver's familiarity with the vehicle, to adjust the speed limiting setting properly.

Mechanical Speed limiter adjusting steps:

1. Loosen the secure nut **A**.
2. Adjust the speed limit screw **B**, turn to the inner angle to reduce the speed, and turn to the out angle to speed up.
3. When adjusting to the proper speed, secure the nut **A**.

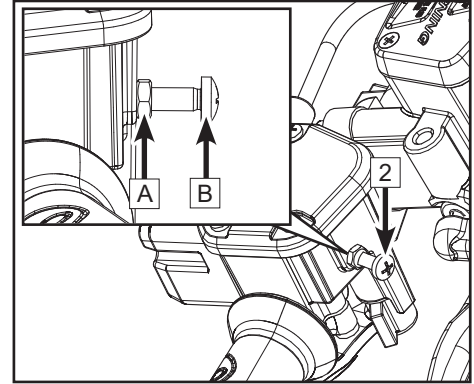

FEATURES & CONTROLS

Foot Brake

(Available in Select Markets)

The foot brake pedal **1** is located on the right side floor board of the vehicle. Pushing down on the pedal applies the rear brakes at the same time.

When applied, the pedal should feel firm. A soft brake pedal would indicate a possible fluid leak or low master cylinder fluid level, which must be corrected before riding. Contact your dealer for proper diagnosis and repair.

WARNING

Operating the ATV with a spongy brake lever or pedal can result in loss of control, which could cause an accident.

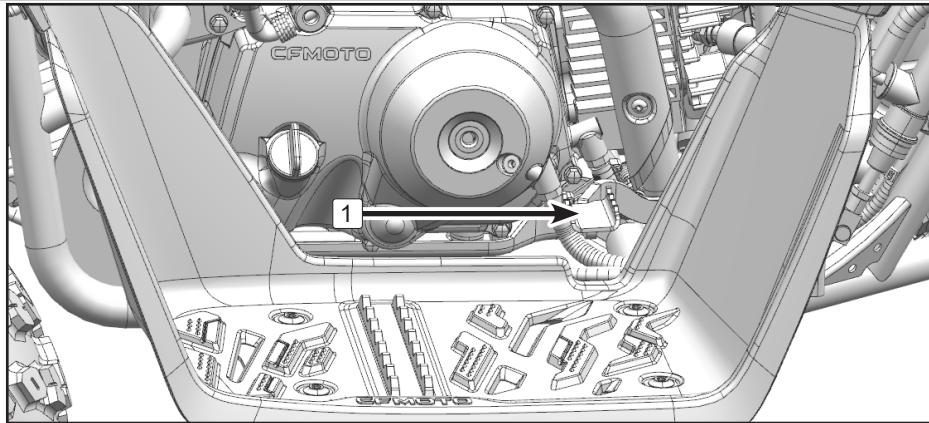

FEATURES & CONTROLS

Foot Brake Reservoir Fluid Level Inspection

The foot brake reservoir **2** is located at the front right side of the vehicle, where the fluid level can be viewed directly.

When the brake fluid is lower than “MIN” level, please fill the reservoir with DOT4 brake fluid to the position between the upper and lower lines.

⚠ WARNING

Never store or use half bottle of brake fluid. Brake fluid is hygroscopic, meaning it rapidly absorbs moisture from the air. The moisture causes the drop of boiling temperature of the brake fluid, which can lead to early brake failing and the possibility of accident or severe injury. After opening a bottle of brake fluid, always discard any unused portion.

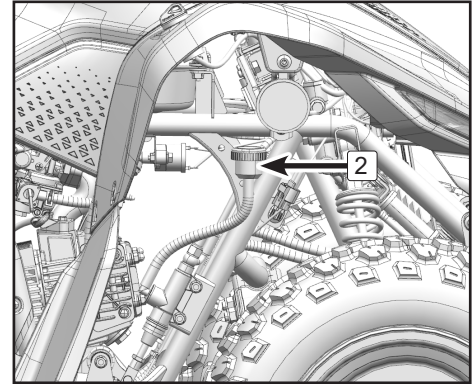

FEATURES & CONTROLS

ELECTRONIC FENCE

(Available in Select Markets)

Electronic fence transmitter (vehicle mounted):

Current input required: DC 12V

Electronic fence receiver (shown at right):

This vehicle is equipped with an electronic fence receiver. The guardian must carry the receiver when the vehicle is used.

The electronic fence receiver is already paired with the vehicle at the factory. There is a QR code on the back that the guardian can scan with the CFMOTO YOUTH App (downloaded on your mobile device) to pair the App with the vehicle.

After pairing, the vehicle can be started or stopped with the receiver or a mobile device using the CFMOTO YOUTH App.

NOTE:

There are three QR code decals.

To prevent loss of QR code stickers, it is advised to stick one on the back of the receiver and the other on the manual.

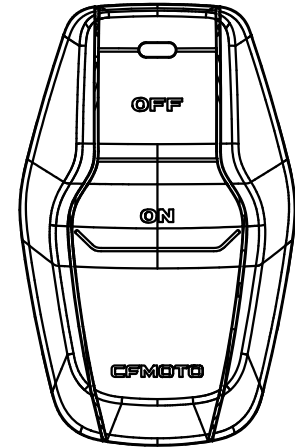

FEATURES & CONTROLS

About CFMOTO YOUTH App

The guardian can set an electronic fence range using the CFMOTO RIDE YOUTH App installed on a mobile device. The app will remind the guardian if an operator is driving out of the electronic fence range and the guardian should alert the operator to return inside the range of electronic fence.

Please refer to the CFMOTO RIDE YOUTH App instructions for setting the electronic fence.

NOTE:

The alarm made by the fence cannot replace guardians' protection and driving instructions.

The fence signal can be affected by obstacles, so it is important to avoid drivers getting out of their guardians' sight.

FEATURES & CONTROLS

Electronic Fence Operation

The functions can be only used inside the available range of the receiver and vehicle.

Range Radius: 0~1312ft (0m ~ 400 m).

Turning on:

Turning on the receiver by long press ON/OFF for 1 second. The receiver's buttons can then be used.

Turning off:

If the receiver is turned on or the vehicle is connected to APP by Bluetooth, and there is no operation for 30 seconds, the receiver will be turned off automatically; Or by long pressing the OFF to shut down the receiver.

Unlocking the vehicle:

Long press ON for 3 seconds to unlock the vehicle, the receiver will vibrate once, the indicator will flash in blue twice, and the alert will sound once; If the vehicle drives out the set range, the receiver will vibrate three times.

Locking the vehicle:

Press OFF for three times within 2 seconds to lock the vehicle, and the receiver will vibrate once, the indicator will flash in blue twice and the alert will sound once.

Setting the electronic fence center

After turning on the receiver, set the vehicle's current location as a center by pressing ON and OFF at the same time, and the receiver will vibrate once, the indicator will flash in blue twice, and the alert will sound once

NOTE:

By default, the receiver is off, so please set the range in the APP.

Operators cannot drive the vehicle while the range is being set.

If the receiver does not locate successfully, the electronic fence is turned off.

FEATURES & CONTROLS

Indicator **1**;

Micro USB charging port **2**;

NOTE:

Charging input allowed by the electronic fence receiver: DC 5V;

If the receiver has a fault, the indicator will not flash and the receiver cannot be charged. If this happens, please contact your dealer.

If the receiver is lost, please contact your dealer.

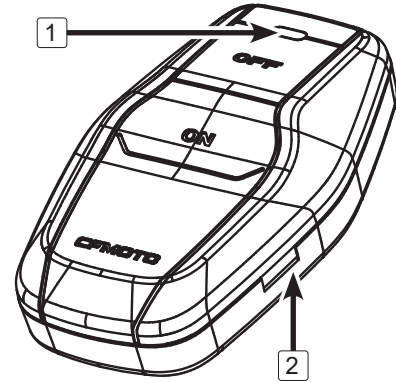

Receiver's indicators:

Number	Indicators	Turn on	Bluetooth connected	Charging when turned off	Fully charged when turned off	Low power
1	Charging indicator	Off	Off	Red	Green	Off
2	Working indicator	Blue	Flash	Off	Off	Off

FEATURES & CONTROLS

Electronic Fence Receiver - Pairing With The Vehicle

1. Ensure the vehicle and receiver are powered off.
2. Power on the vehicle, then turn on the receiver and complete the steps 3 and 4 within one minute; if it takes more than a minute, please power off and then power on the vehicle, and turn on the receiver again.
3. Hold the receiver close to the front service cover (20 cm away from the transmitter). Press OFF, press ON, then double press OFF (These operations must be completed within 2 seconds).
4. When the vehicle alert emits a short sound, the pairing is finished. A long sound means too much distance.
5. If there is no response, please repeat the steps 1-4 until the pairing is finished.
6. Apply a back-up QR sticker to the back of the receiver 1 if required. Scan the QR code to pair with a mobile device using the CFMOTO YOUTH App.

Transmitter location (1) is under the front cover as shown:

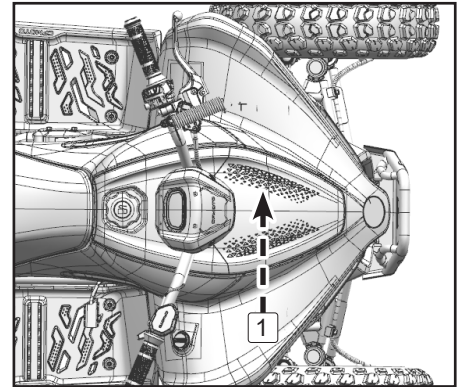
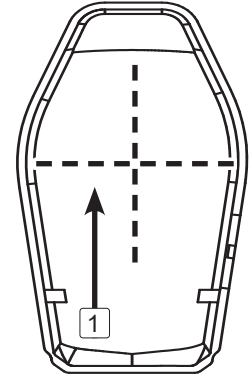

FEATURES & CONTROLS

Electronic Fence Receiver QR Code

Please apply a QR code sticker at this position:



Device Codes (ten numbers and characters):

Guardians can input the device code on the CFMOTO YOUTH App to connect the receiver. Device codes can be obtained from a backup QR code and a label on the vehicle's electric fence transmitter. Both codes are the same in terms of the first nine codes. The last character 'R' represents the receiver, and 'T' for transmitter.

If guardians lose the receiver, its code can be calculated with the help of the transmitter code, and they can temporarily control the vehicle through the CFMOTO YOUTH App.

(Temporary controllable distance: 5m)

When guardians have a new receiver and pair it with the vehicle, it is recommended to stick the back-up QR code on the back of the new receiver.

FEATURES & CONTROLS

Fuel Tank

Fuel tank cap is located at the front of the vehicle. Open the fuel tank cap **1** to fill fuel.

Fuel Minimum Octane Rating

The recommended fuel for your ATV is minimum 95 Octane unleaded (maximum 10% ethanol is allowed). Non-oxygenated (ethanol-free) fuel is recommended for best performance in all conditions.

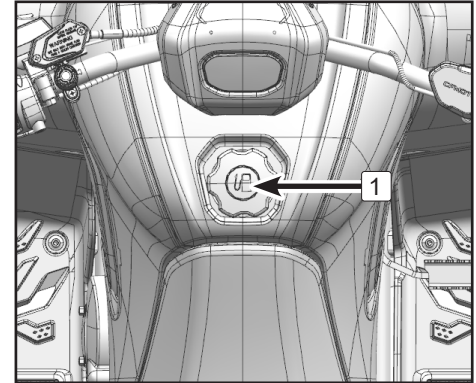

Key Switch

The key switch is at the right front side of the vehicle.

NOTE

Remove and store the spare key. You can only duplicate a key when you have an existing key. If you have lost both keys, then the key switch must be replaced.

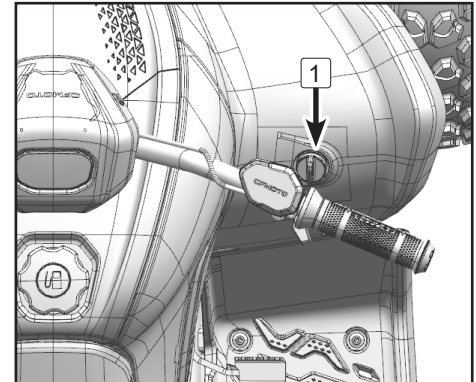

FEATURES & CONTROLS

Gear Shift Lever(state No.1)

Gear Shift Lever **1** is located at the right front side of the vehicle.

CAUTION

Before shifting the gear, the ATV should be stopped and foot brake should be applied. If operators are shifting when the motor RPM is higher than the idling speed or the vehicle is moving, transmission damage may occur.

F – Forward. In forward position the vehicle can move forward.

N – Neutral. In neutral position the engine power output is disengaged.

R – Reverse. In reverse position, the vehicle can move backwards.

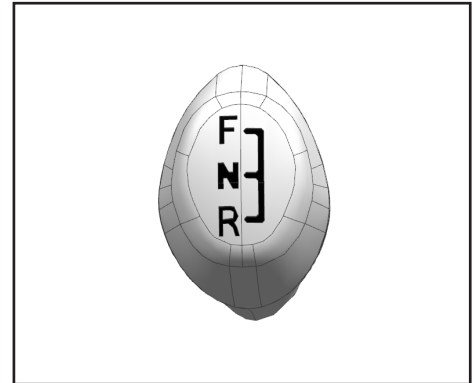
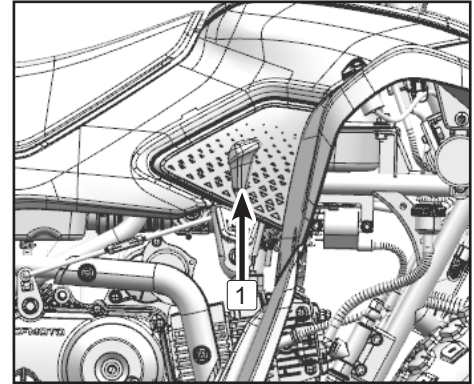

FEATURES & CONTROLS

Gear shift pedal (state No.2)

Gear shift pedal 1 is located at the left side of the vehicle.

WARNING

Before shifting the gear, the ATV should be stopped and foot brake should be applied. If operators are shifting when the motor RPM is higher than the idling speed or the vehicle is moving, transmission damage may occur.

F - Forward, in forward position the vehicle can move forward.

N - Neutral, in neutral position the engine power output is disengaged.

R - Reverse, in reverse position, the vehicle can move backwards.

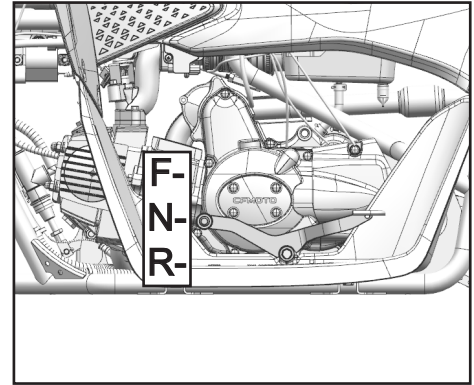

FEATURES & CONTROLS

Front Service Cover

Your vehicle is equipped with a service board at the front.

Removal:

1. Remove the seat;
2. Remove the fuel tank cap;
3. Remove two bolts at the fuel tank's rear cover, and remove the rear cover;
4. Remove two screws at the fuel tank's front cover, and remove the front cover.

Installation:

1. Install the front cover and mount two screws;
2. Remove the fuel tank cap;
3. Install the rear cover and mount two screws;
4. Install the fuel tank cap and seat cushion.

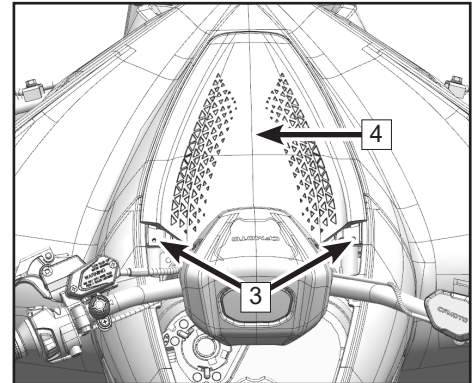
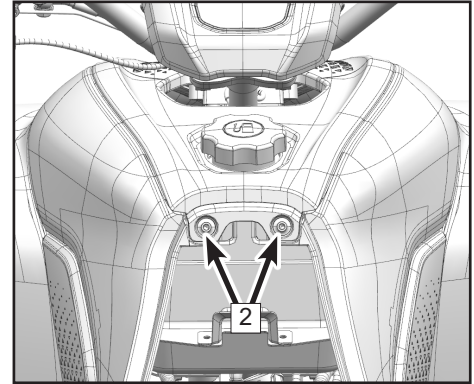

FEATURES & CONTROLS

Tool Kit

Tool Kit **1** is located under the seat.

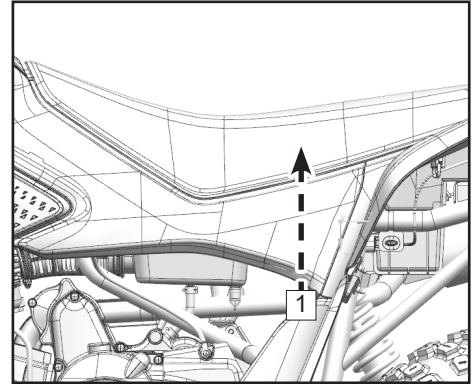

Seat

The seat lock **1** is under the seat at the vehicle rear.

To remove, pull the lock outward and remove the cushion **2**.

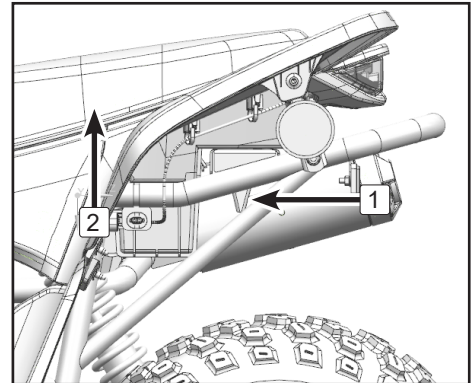

FEATURES & CONTROLS

Dashboard Indicators and Warnings

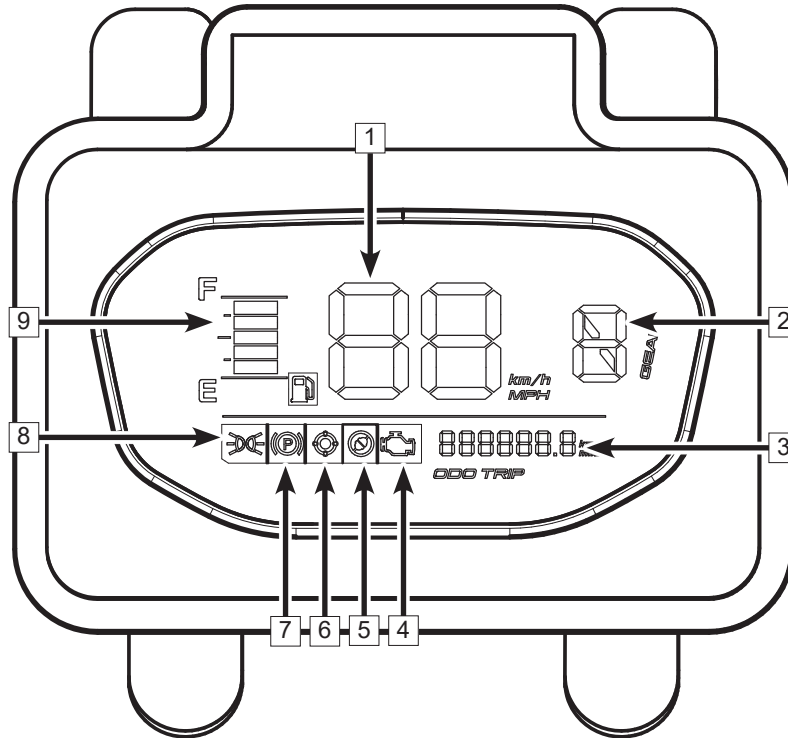

FEATURES & CONTROLS

1	Speedometer	2	Gear Position Display	3	Odometer
4	EFI fault indicator	5	Safety Lock State Indicator	6	Electronic Fence Indicator
7	Parking indicator	8	Headlight Indicator	9	Fuel Gauge

1. Speedometer

The current speed is displayed here.

(Unit setting: Quickly shift the light switch 5 times within 5 seconds after powering on the vehicle.)

2. Gear Position Display

The current gear is displayed here. (Part of the market instrument is equipped with gear display only)

Neutral position, the N is displayed;

Reverse position, the R is displayed;

Forward position, the F is displayed.

3. Odometer

The Odometer is displayed here.

(Odometer and mileage are shifted automatically within 10 seconds after powering on the vehicle.)

4. EFI fault indicator (When the vehicle is equipped with EFI)

a. This indicator is on when a fault occurs in the Electronic Fuel Injection system. Please stop the vehicle and contact your dealer to eliminate the fault, or it may result in serious engine damage.

b. When the vehicle is powered on but the engine is not turned on, the indicator is on.

5. Safety Lock State Indicator

This indicator will light on when safety lanyard is taken off the safety lock.

FEATURES & CONTROLS

6. Electronic Fence Indicator (Available in Select Markets)

This indicator will be on when the vehicle is out of the range of electronic fence.

This indicator will be on when the vehicle is out of the range of electronic fence. The guardian can set electronic fence range in the mobile CFMOTO RIDE YOUTH App. The App will remind the guardian that operator is driving out of the electronic fence range and should return back inside the range.

(Please refer to the CFMOTO RIDE YOUTH App instructions for setting electronic fence range.)

7. Parking Indicator

The function is not available, the indicator will only flash once when the vehicle is started.

8. Headlight Indicator

When the headlight is turned on, the indicator is on.

9. Fuel Gauge

The amount of fuel remained is displayed here. When the fuel is less than 2L, the indicator flashes and gives an alarm.

OPERATING YOUR VEHICLE

Break-In Period

The break-in period for a new engine is very important. Careful treatment of a new engine at the beginning of ownership will contribute to more efficient performance and longer life. Perform the following procedures carefully:

1. Select an open area that allows room to familiarize yourself with vehicle operation and handling.
2. Place the vehicle on a level surface.
3. Fill the fuel tank with gasoline.
4. Check the engine oil level. Add the recommended oil if necessary to maintain the oil level between the minimum and maximum indicators on the dipstick.
5. Sit in the operating position on the vehicle, fasten the seatbelt (if equipped) and safety nets or side doors, and start the engine. Allow the engine to idle for a short period before operating.
6. Press the foot brake, select the desired gear, and then release the foot brake.
7. Apply throttle. Drive slowly at first, up to $\frac{1}{2}$ throttle for 10 hours or 100 miles (160 Km), then another 10 hours or 100 miles (160 Km) up to $\frac{3}{4}$ throttle. Do not operate at a sustained idle speed or with throttle wide open constantly.
8. Do not pull or carry heavy loads during the break-in period.
9. Periodically check fluid levels, controls, etc. along with the items outlined in the periodic maintenance chart.
10. At the end of the break-in period, change the engine oil (20 hours or 200 miles / 320 km).

OPERATING YOUR VEHICLE

WARNING

When the vehicle is being started, please grip the handbrake or step on the footbrake.

Gear Shifting

Follow these steps to shift the gear:

- Make sure the throttle is off and the vehicle is completely stopped;
- Gear can be shifted to F, N, or R;
- When shifting to Forward, F is displayed on the dashboard;
- When shifting to Neutral, N is displayed on the dashboard;
- When shifting to Reverse, R is displayed on the dashboard;

WARNING

Make sure the vehicle is completely stopped before any gear shifting operation.

The dashboard will display the current gear position, if the display is not correct, please contact your CFMOTO dealer to inspect the circuits of the shifting system.

Never load any cargo on this vehicle.

Reverse driving is dangerous, make sure there are no people or obstacles at the rear of the vehicle, keep the vehicle at a slow speed when operating in reverse gear.

OPERATING YOUR VEHICLE

Responsibility of Operators and Guardians

The driver should be supervised by a parent or guardian at all times.

The driver should wear the required safety riding gear.

Recreational, Group, and Distance Riding

One of the benefits of this vehicle is that the operator can go off-road driving under the supervision of parents or guardians within allowed areas, such as trails for snowmobiles, equestrian, mountain bikes or other places designated for ATV use. Stay away from areas designated for other types of off-road use unless it is specifically allowed.

Avoid Accidents or rollover

The parent or guardian should pay attention to the operator's driving to avoid accidents.

Abrupt operation can lead to rollover or other accidents, such as:

- Turning at sharp angles or at excessive speeds.
- Driving on hills or crossing over obstacles.

OPERATING YOUR VEHICLE

Follow the items below to reduce the risk of accidents:

- Be careful when making turns, and reduce speed before entering into turns.
- Select suitable turning angles according to the speed and environment.
- Do not make abrupt or hard braking actions when turning.
- Do not make sudden throttle changes during turning or at slow speeds.
- Never attempt wheelies, skidding, fishtailing, jumps or other stunts.
- If the vehicle happens to skid, turn the steering in the same direction the rear of the vehicle is skidding.
- This vehicle is designed for off-road use. Driving on paved surfaces is more likely to influence the handling. Do not travel on sidewalks or bicycle lanes, as they are not designated for ATV use. If you must drive on a paved surface, reduce speed and avoid sudden turns, acceleration, or braking.

This vehicle can roll over sideways, or tip over forward or backwards on slopes or uneven terrain:

- Avoid driving on side-hills (driving along the slope rather than up or down a hill). When possible, drive straight up and down rather than across hills. If you must drive on side-hills, use extreme caution and avoid slippery surfaces, objects, or depressions. If you feel the vehicle start to roll over or slide sideways, steer downhill if possible.
- Avoid steep hills and follow the procedures in this manual for climbing and descending hills.
- Sudden changes in terrain such as holes, depressions, banks, softer or harder ground or other irregularities may cause the vehicle to tip or become unstable. Observe the terrain ahead and slow down in areas of uneven terrain.

OPERATING YOUR VEHICLE

Avoiding Collisions

Never operate at excessive speeds. Always operate at a speed that is proper for the terrain, visibility, and operating conditions, and your experience.

This vehicle does not have the same kind of protection for collisions as a car; for example, there are no air bags, no cab that is fully enclosed, no safety belt, and it is not designed for collisions with other vehicles. Therefore, it is particularly important to operate carefully, and wear proper riding gear.

Environment

- Off-road recreation is a privilege. Maintain your privilege, and at the same time please respect the environment and the rights of others to enjoy it:
- Chasing wildlife is illegal. Wildlife can die of exhaustion if chased by a motorized vehicle.
- Never purposely damage the terrain unless the operating area is designated for that type of activity.
- Observe the rule "what you take in, take it out". Do not litter.

OPERATING YOUR VEHICLE

Practice Exercises

Before you go out for a ride, it is very important to familiarize yourself with the handling of your vehicle by practicing in a controlled environment.

Under the protection of a parent or guardian, find a suitable area to practice and perform the following exercises. It should be flat terrain, and free of obstacles like trees and large rocks.

If an incorrect driving technique is used, your ATV may continue to go straight. If the ATV does not turn, slow the vehicle and then practice the procedure again. If the riding surface is slippery or loose, it may help to transfer more of your weight to the front wheels by moving forward on the seat. Once you have learned the proper techniques, you should be able to perform maneuvers at higher speeds or in tighter curves.

Improper driving procedures such as abrupt throttle changes, excessive braking, incorrect body movements, or too much speed for the sharpness of the turn, may cause the ATV to tip. If the ATV begins to tip over to the outside while turning, lean more to the inside. It may also be necessary to gradually release the throttle and steer to the outside of the turn to avoid tipping over.

Remember: Avoid higher speeds until you are thoroughly familiar with the operation of your ATV.

OPERATING YOUR VEHICLE

Basic Operation Steps

Familiar yourself with start on and shifting operations, then practice the following basic steps:

- Check your surroundings and determine your path of travel.
- Sit upright with both feet on the footrests and both hands on the handlebars.
- Press “START” button to power on the vehicle.
- Apply the brakes and shift the gear switch to the forward (F) gear position.
- Release the brakes.
- Slowly press the throttle lever with your right hand. Throttle operation should be slowly and steady. The vehicle speed is controlled by the open angle of the throttle lever. Strong throttle lever movements could lead the vehicle to accelerate suddenly.
- While driving, practice throttle and brake operation.
- Familiarize yourself with the throttle and braking operation, then learn the turning and reversing operation and others.

OPERATING YOUR VEHICLE

Turning Exercises

Turning is a basic driving technique, and it is one of the most frequent causes of accidents. It is easy for the vehicle to lose traction or rollover if you turn too sharply, or go too fast while turning. Slow down when you approach a turn.

Practice turning:

- Drive at low speeds.
- Release the throttle.
- Check the path of travel, make sure there are no obstacles.
- Apply the throttle lever slowly, then turn the handlebars and steer in the direction of the turn you wish to make. The turning angle should be large enough to reduce the risk of rollover. Lean your upper body to the inside of the turn while supporting your weight on the outside footrest. This technique alters the balance of traction between the wheels, allowing the turn to be made smoothly.
- Turn back the handlebar after the vehicle has completed the turn.
- After familiar with the operations above, try to practice turning while retaining a stable throttle.
- Practice turning to the other direction in the same way and make U-turns to the left and right.
- After you are familiar with the slow speed turning operation, attempt to turn at faster speeds.

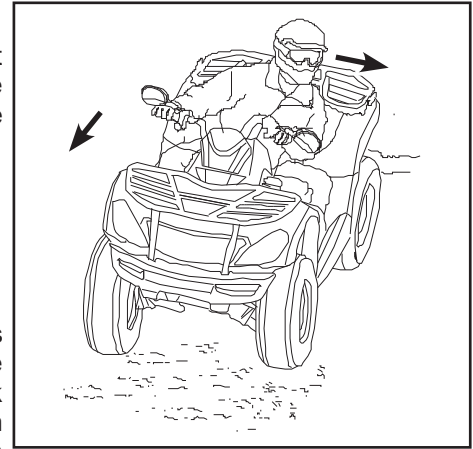

OPERATING YOUR VEHICLE

WARNING

Turning sharp angles or at excessive speeds can result in vehicle's rollover and lead to serious injury.

The higher the turning speed, the higher the risk of rollover. It is prohibited to turn at high speeds.

Abrupt changes of throttle during turning may lead to loss of balance or rollover.

Never practice on paved surfaces. The different operating habits and driving feeling may add the risk of rollover.

The actual conditions for turning can be complicated. Please always keep alert and reduce speed, and use flexibly all the skills you have learned.

OPERATING YOUR VEHICLE

Reverse Exercise

Reverse is another basic driving technique. Due to the vision limitation, reversing operation is more dangerous than normal driving actions. Please check the surroundings carefully to reduce the risk of accidents.

Reverse Vision

ATV has smaller blind spots, but it is still important to keep alert.

- Place a cone marker on both sides of the vehicle beside each rear wheel.
- Move the vehicle forward until you can see the cone markers behind you through rear mirrors or by turning your head.
- Stop your vehicle and know your blind spots, and be on high alert in follow-up operations.

Follow the steps to practice reverse:

- Shift to 'R'.
- Check for any people, obstacles or downhill slopes behind you.
- After making sure it is safe, release the foot brake pedal and press the throttle lever gradually.
- Familiar yourself with the vehicle feedback during reverse operation.

OPERATING YOUR VEHICLE

Practice turning during reverse following the steps below:

- Shift to “R”.
- Check if any people, obstacles or downhill behind you.
- Steer in the direction of the turn, with the turning angle as large as possible to reduce the risk of rollover. Lean your upper body to the inside of the turn while supporting your weight on the outer footrest. This technique alters the balance of traction between the wheels, allowing turn to be made smoothly and flexibly.
- Turn back the handlebar after the turn is completed.
- Familiarize yourself with the vehicle feedback during reverse turning operation.
- Repeat the turning exercise for the other direction.

WARNING

Do not operate at wide open throttle. Never change the throttle abruptly. Open the throttle just enough to maintain a desired speed.

Never reverse downhill. Gravity will increase the speed beyond the limited reverse speed. Failure to use caution when operating in reverse can result in serious injury or death.

Applying brake mildly when reverse could help better operation of the vehicle.

Never make sharp turns during reverse operation.

OPERATING YOUR VEHICLE

Off-Road Operation

Off-road operation on natural terrain is dangerous. Any terrain which has not been specially prepared to carry vehicles presents an inherent danger where terrain substance, shape, and steepness are unpredictable. The terrain itself presents a continual element of danger, which must be knowingly accepted by anyone venturing over it.

OPERATING YOUR VEHICLE

Driving on Slippery Surfaces

Slippery surfaces include wet trails, loose gravel or any surfaces during freezing weather.

Slippery surfaces will result in skidding, rollover, longer braking distance and so on. Driving on cobblestone surfaces may cause loose stones to be ejected, which could hit other people or influence other's routine.

Follow the precautions when driving on slippery surfaces:

- Slow down when entering slippery areas.
- Never enter an unfamiliar slippery area.
- Maintain a high level of alertness, familiar with the trail and avoiding quick, sharp turns which can cause skidding.
- Correct a skid by turning the handlebars in the direction of the skidding and shifting your body weight forward.
- Never apply the brakes during a skid.

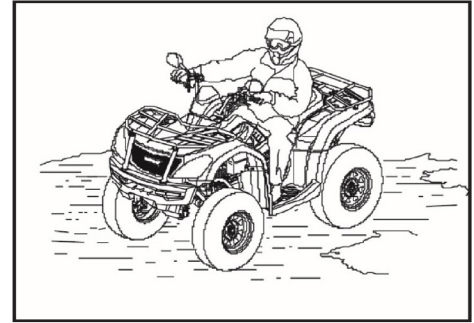

OPERATING YOUR VEHICLE

Driving on Rough Terrain

- Never drive in rough terrain.

Driving over Obstacles

Obstacles include rocks, fallen trees, and depressions.

Improperly crossing over obstacles may lead to rollover or lead people to be ejected out of the vehicle.

Follow these precautions:

- The best precaution is to avoid crossing over obstacles whenever possible.
- Never attempt to cross an obstacle higher than the ground clearance of the vehicle.
- Try best to keep vertically with the obstacle when crossing the obstacle.
- Adjust speed without losing momentum and do not accelerate abruptly.



OPERATING YOUR VEHICLE

Driving on Hillsides

Operating on hillsides for young drivers is not recommended.

If it is unavoidable to drive on hillsides, please observe the following precautions:

Uphill Driving

Whenever traveling uphill, follow these precautions:

- Check the slope, avoid steep hills with a slope of 10° .
- Keep your center of gravity forward.
- Always travel straight uphill and keep a steady speed.
- Keep both feet on the footrests, grasp both handlebars to avoid loss of balance.
- Remain alert and be prepared to take emergency actions.
- If you feel the slope is getting too steep to climb, or forward speed is lost and it is hard to continue to climb the hill, apply brakes to stop the vehicle, and give up this route if possible.
- If the vehicle begins to roll backward with no control when driving uphill, apply brakes to stop the vehicle.

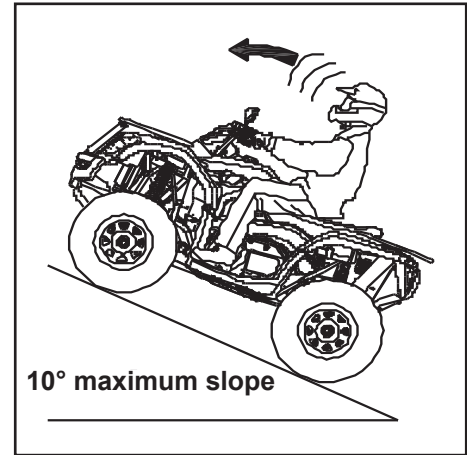

OPERATING YOUR VEHICLE

Driving Downhill

When traveling down a hillside, follow these precautions:

- Check the slope, avoid steep hills with a slope of over 10°.
- Keep your center of gravity backward.
- Always travel straight downhill and keep a steady speed.
- Keep both feet on the footrests, grasp both handlebars to avoid loss of balance.
- Apply brakes lightly to reduce your speed if necessary.

WARNING

Excessive downhill speed can cause loss of control and lead to serious injury or death. Always reduce speed before traveling downhill.

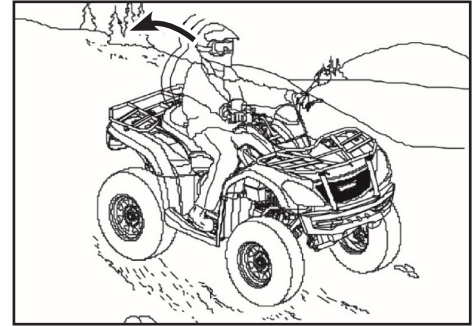

Driving over Peaks

When traveling over peaks of a hill, follow these precaution:

- Keep a steady speed to travel over the top of hill, and reserve enough time to react to terrain differences on the other side of the hill.

MAINTENANCE

Careful and periodic maintenance will help keep your vehicle in the safest, most reliable condition. Inspection, adjustment, and lubrication of important components are explained in the Periodic Maintenance Chart.

Inspect, clean, lubricate, adjust, and replace parts as necessary. When inspection reveals the need for replacement of certain parts, always use original parts from your dealer.

 NOTE

Periodic maintenance and adjustments are critical. If you are not familiar with relative procedures, have a qualified dealer perform maintenance for you.

Severe Use

CFMOTO defines severe use of the vehicle as:

- Extreme hot weather operation
- Extreme cold weather operation
- For commercial use
- Racing or race-style use

If your vehicle will be used in a way that matches any of these definitions, decrease the maintenance schedule intervals by 50%.

NOTE:

Owners should adjust periodic maintenance intervals according to actual operating conditions, driving environment and other factors. The recommended maintenance periods that CFMOTO suggests is based on general use of the vehicle under ideal driving conditions. Observe and record the use of tires, the drive system and braking system, and flexibly adjust your periodic maintenance accordingly, rather than rigid following of the recommended maintenance schedule. If your driving environment is ideal and operation is smooth, please follow the standard intervals for maintenance. If your driving conditions are severe, usage is harsh, or driving time increases frequently, please consult a CFMOTO authorized dealer for more reasonable suggestions about maintenance intervals. Do not determine the maintenance intervals by yourself, which could seriously affect the driving experience and service life of your vehicle.

 WARNING

Procedures marked as '■' means if repair is required, and have an authorized dealer perform repairs that relate to this component or system. Improperly performing the procedure could result in component failure and lead to serious injury or death.

KEY POINTS OF LUBRICATION SCHEDULE:

Check all components at the intervals outlined in the Periodic Maintenance Chart. Items not listed in the schedule should be lubricated at the general lubrication interval.

- Change lubricants more often under severe conditions, such as being used in wet or dusty conditions.
- Use All Season Grease on pivot points.
- For every 900 km, lubricate before long periods of storage, after pressure washing, or after submerging drive system.

Item	Specifications	Method
Engine oil	SAE 10W-40 / SAE 5W-40 / SAE 15W-40	Inspect the oil level from the oil view window.
Brake fluid	DOT4	Keep the level between upper and lower lines.

Pre-ride Maintenance Check

Before each use of the vehicle, a best practice is to check the vehicle according to the Pre-ride Maintenance Check.

WARNING

If a proper inspection is not done before each use, severe damage to the vehicle, severe injury, or death could occur. Always inspect the vehicle before each use to ensure it is operated properly.

Item		Maintenance before each use			Notes
		Hour	Schedule	Miles (km)	
■	Steering system	--	Pre-Ride	--	Visually inspect, test, or check components. Make adjustments and/or schedule repairs when required.
■	Throttle return	--	Pre-Ride	--	
	Front suspension and axles	--	Pre-Ride	--	
	Rear suspension and axles	--	Pre-Ride	--	
	Tires	--	Pre-Ride	--	
	Brake fluid level	--	Pre-Ride	--	
	Brake lever / foot brake function	--	Pre-Ride	--	
	Brake system function	--	Pre-Ride	--	
	Wheels / fasteners	--	Pre-Ride	--	
■	Lights	--	Pre-Ride	--	Inspect. Replace them with new ones if necessary.

Break-in Periodic Maintenance Chart

Maintain the following item that reaches the interval first within 20 hours or specified intervals.

Item		▲ Break-in Maintenance Interval (Maintain the item that reaches the interval first)			
		Hour	Month	Miles (km)	Notes
	General lubrication	20	-	200 (320)	Lubricate all grease points, pivots, cables, etc.
	Engine oil	20	-	200 (320)	Change oil
▶	Engine air filter	20	-	200 (320)	Inspect; replace if dirty; do not clean
■	Engine valve clearance	20	-	200 (320)	Check and adjust as necessary.
▶	Brake pad	20	-	200 (320)	Inspect the thickness.

▲ = The maintenance interval is shortened by 50% for vehicles subjected to severe use.

■ = Have an authorized dealer repair involved components and systems.

▶ = Have an authorized dealer repair involved emission components or systems.

Item		▲ Break-in Maintenance Interval (Maintain the item that reaches the interval first)			
		Hour	Month	Miles (km)	Notes
	Battery	20	-	200 (320)	Check terminals, clean, test battery condition if required
■	Idle condition	20	-	200 (320)	Test proper rpm. Contact dealers for maintenance if the rpm is out of spec or erratic
■	Steering / Wheel Alignment	20	-	200 (320)	Inspect steering system. Contact dealers for maintenance if wheel alignment is required.
▶	Foot brake / Hand brake	20	-	200 (320)	Inspect function. Adjust if necessary.
	Engine hoses, gaskets and seals	20	-	200 (320)	Inspect for leaks.

▲ = The maintenance interval is shortened by 50% for vehicles subjected to severe use.

■ = Have an authorized dealer repair involved components and systems.

● = Have an authorized dealer repair involved emission components or systems.

Periodic Maintenance Schedule

Maintain the following item that reaches the interval first after 20-hour break-in period.

Item		▲ Periodic Maintenance Interval (Maintain the item that reaches the interval first)			
		Hour	Month	Miles (km)	Notes
▶	Brake pad	10	1	100 (160)	Inspect pad thickness.
	Battery	20	-	200 (320)	Check terminals. Clean and test battery condition if necessary.
	Engine hoses, gaskets and seals	20	-	200 (320)	Inspect for leaks.
▶	Air filter	50	-	500 (800)	Always inspect before each use. Inspect frequently if subjected to severe use. Replace if dirty. Do not clean.
▶	General lubrication	50	3	500 (800)	Lubricate all grease points, pivots, cables, etc.
▶	Engine oil	100	12	1000 (1600)	Inspect for color change. Change if dirty. Change yearly if hours or distance interval is not met.

▲ = The maintenance interval is shortened by 50% for vehicles subjected to severe use.

■ = Have an authorized dealer repair involved components and systems.

● = Have an authorized dealer repair involved emission components or systems.

Item		▲ Periodic Maintenance Interval (Maintain the item that reaches the interval first)			
		Hour	Month	Miles (km)	Notes
▶	Radiator	50	6	500 (800)	Inspect; clean external surfaces. Clean more frequently if subjected to severe use.
■	Steering system	50	6	500 (800)	Inspect. Lubricate.
▶	Front suspension	50	6	500 (800)	Lubricate. Check fasteners.
▶	Rear suspension	50	6	500 (800)	Lubricate. Check fasteners.
▶	Gear shift	50	1	500 (800)	Inspect, lubricate, and adjust if necessary.
▶ ■	Throttle body / throttle cable	50	6	500 (800)	Inspect. Clean carbon deposits. Inspect cable and lubricate frequently if subjected to severe use.

▲ = The maintenance interval is shortened by 50% for vehicles subjected to severe use.

■ = Have an authorized dealer repair involved components and systems.

● = Have an authorized dealer repair involved emission components or systems.

Item		▲ Periodic Maintenance Interval (Maintain the item that reaches the interval first)			
		Hour	Month	Miles (km)	Notes
	Fuel filter and hoses	100	24	2000 (3200)	Inspect routing. Replace filter and high-pressure hoses every 4 years.
▶	Valve clearance	100	-	2000 (3200)	Inspect and adjust if necessary. Contact dealers for maintenance.

▲ = The maintenance interval is shortened by 50% for vehicles subjected to severe use.

■ = Have an authorized dealer repair involved components and systems.

● = Have an authorized dealer repair involved emission components or systems.

Item		▲ Periodic Maintenance Interval (Maintain the item that reaches the interval first)			
		Hour	Month	Miles (km)	Notes
●	Fuel system	100	12	500 (800)	Inspect fuel tank, cap, fuel pump and fuel pump relay.
	Spark plug	100	24	2000 (3200)	Inspect; Replace if worn or fouled.
■	Engine bracket	100	12	1500 (2400)	Inspect.
	Exhaust pipe and spark arrestor	100	12	500 (800)	Inspect and clean.
▶	Wiring, fuses, connectors, relays, and cables	100	12	1000 (1600)	Inspect wire routing for wear and ensure security. Apply dielectric grease if necessary to connectors subjected to water, mud, etc.

▲ = The maintenance interval is shortened by 50% for vehicles subjected to severe use..

■ = Have an authorized dealer repair involved components and systems.

● = Have an authorized dealer repair involved emission components or systems.

Item		▲ Periodic Maintenance Interval (Maintain the item that reaches the interval first)			
		Hour	Month	Miles (km)	Notes
▶ ■	Bearings	100	12	1500 (2400)	Inspect for noise or looseness. Replace if necessary.
▶	Brake fluid	200	24	1000 (1600)	Inspect fluid color change. Change brake fluid every two years.
	Idle condition	-	12	-	Test proper rpm. Contact dealers for maintenance if the rpm is out of spec or erratic.
■	Steering /Wheel alignment	-	12	-	Inspect steering system. Contact dealers for maintenance whenever steering parts or wheel alignment are required.
▶	Foot brake height	-	12	-	Inspect. Replace brake pads or adjust height if required.

▲ = The maintenance interval is shortened by 50% for vehicles subjected to severe use.

■ = Have an authorized dealer repair involved components and systems.

● = Have an authorized dealer repair involved emission components or systems.

Engine Oil Inspection

Inspect the Engine Oil Level

- Place and park the vehicle on level ground.
- Start and idle the engine for 30 seconds, and then stop the engine.
- Wait for a short time to allow the engine oil to settle down inside the engine.
- Remove the oil dipstick **1** and clean it.
- Insert the oil dipstick into the dipstick hole (do not fully reinstall it).
- Remove the oil dipstick and ensure that the oil level is between upper and lower marks.
- Reinstall the oil dipstick and tighten it.

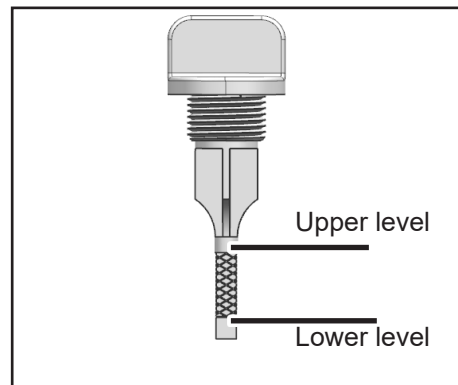
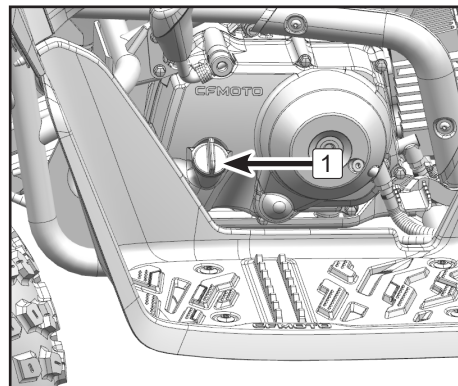

Engine Oil Change

- Place and park the vehicle on level ground.
- Start and idle the engine for 2-3 minutes, and then stop the engine.
- Place a pan under the engine oil drain hole **1** to collect the used engine oil.
- Remove the dipstick and clean it.
- Remove the magnetic drain bolt to drain out the oil.
- Make sure the engine oil in the crankcase is drained completely.
- Install and tighten the drain bolt to the specified torque.

Drain Bolt Torque: 18.5 ft-lb. (25 N·m)

- Use a dry and clean cloth to wipe the area around magnetic drain bolt.
- Add the recommended type of oil into oil dipstick hole to the specified range by using the funnel assembly of funnel, funnel extension tube and tube adapter.
- Remove the funnel assembly, make sure the oil level is between the upper and lower marks with the dipstick, and adjust the oil level accordingly.

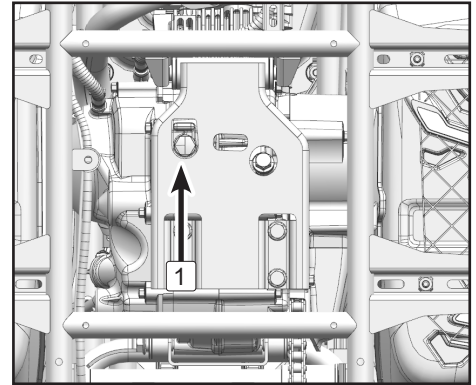

 **NOTE**

Too much or too little oil will have an impact on the normal operation of the engine. Make sure the oil is maintained between the upper and lower marks of the dipstick.

- Install and tighten the oil dipstick.
- Make sure the vehicle is parked, and then start and idle the vehicle for 30 seconds.
- Inspect the engine for leaks after turning off the engine. Contact your dealer if leaks are found.

 **WARNING**

When changing the engine oil, turn off the vehicle and keep it parked to avoid any injury or death.

- Dispose the used oil and filter in a proper way.

Air Filter

There is a check hose **1** at the bottom of the air filter housing. If dust or water can be viewed in this hose, empty the hose and clean the air filter housing thoroughly.

NOTE: If there is a large amount of water in the air filter, have your dealer check the engine crankcase.

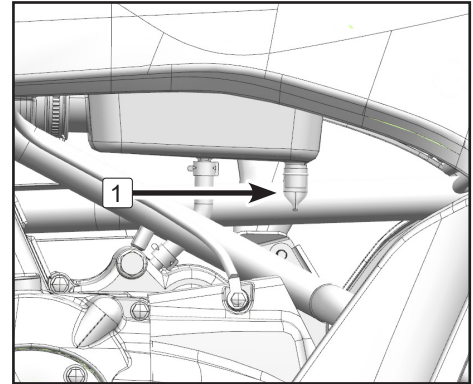

Air Filter Maintenance

- Remove the seat;
- Loosen clamps **2**;
- Remove the air filter cover **3**;
- Remove clamps **3**;
- Remove the filter element **4**;
- Remove the air filter steel screen **5**;

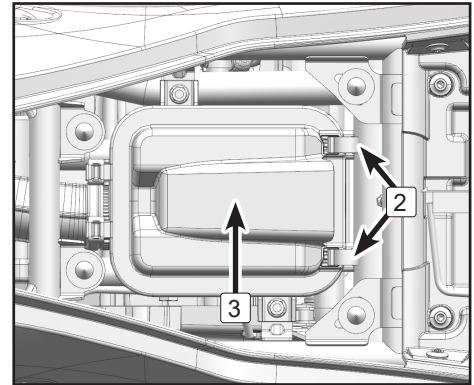

- Install the steel screen and a filter element. Apply a layer of lubricating oil on the inner diameter of air filter rubber sealing ring.
- Install air filter cover and clamps. Ensure the filter is installed correctly and completely sealed.

NOTE

The air filter must be checked and replaced more often if the machine is operated in extremely dusty areas or if it becomes wet. Each time air filter maintenance is performed, check the air inlet to the air filter box for obstructions, the fittings of the air filter housing rubber joint, throttle body, and manifold for an airtight seal. Check that all fittings are tightened securely to avoid the possibility of unfiltered air entering the engine.

CAUTION

Do not start engine without air filter element. Non-filtered air will enter into the engine and cause engine wearing and damage. In addition, driving without air filter will also decrease performance and cause engine overheating.

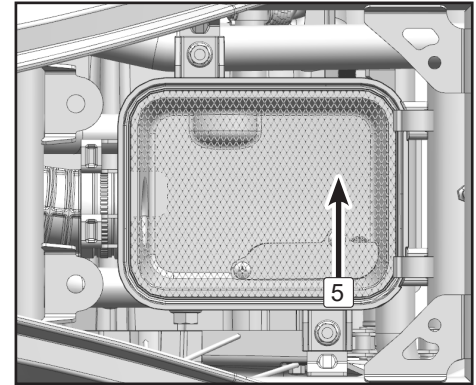
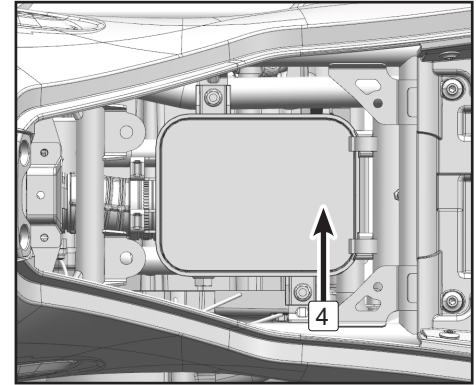

Spark plug inspection

Remove the spark plug cap.

Use the spark plug wrench in the tool kit to remove the spark plug.

Inspection

The spark plug is an important engine component and is easy to inspect. The condition of the spark plug can indicate the condition of the engine. The ideal color on the white insulator around the center electrode is a medium-to-light tan color for a ATV that is being ridden normally. Do not attempt to diagnose such problem yourself. Instead, take your ATV to a dealer. You should periodically remove and inspect the spark plug because heat and deposits will cause the spark plug to slowly break down and erode. If electrode erosion becomes excessive, or if carbon and other deposits are excessive, you should replace the spark plug with the specified plug.

Specified spark plug: A7RTC

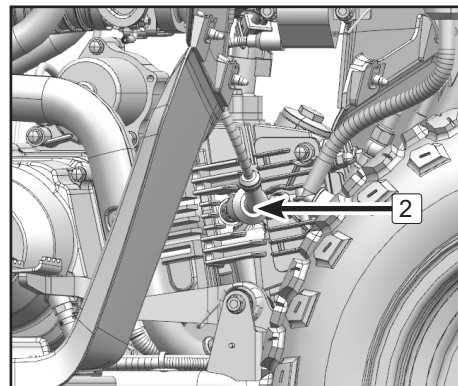

Measure the electrode gap with a thickness gauge, and if necessary, adjust the gap to specification.

NOTE: Spark plug gap [a]: 0.6 mm ~ 0.7 mm

Installation

1. Clean the gasket surface. Wipe off any grime from the threads.
2. Install spark plug and tighten to specified torque.

NOTE: Spark Plug Torque: 8.8 ft-lb. (12 N•m)

If a torque wrench is not available when you are installing a spark plug, a good estimate of the correct torque is 1/4 to 1/2 turn past finger tight. Have the spark plug tightened to the specified torque as soon as possible.

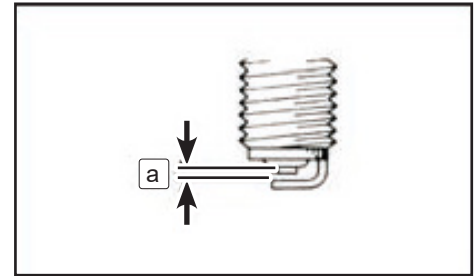

Spark Arrestor

Clean the spark plug arrestor when the muffler and exhaust pipe is at a normal temperature.

- Remove nuts(1);
- Remove the spark arrestor(2);
- Tap the exhaust pipe gently and use a steel brush to clean any carbon deposits from the spark arrestor;
- Install the muffler in the exhaust pipe;
- Install nuts.

WARNING

When cleaning the spark arrestor: please make sure the exhaust pipe is totally cooled before you touch its parts. Do not start the engine when cleaning the exhaust system.

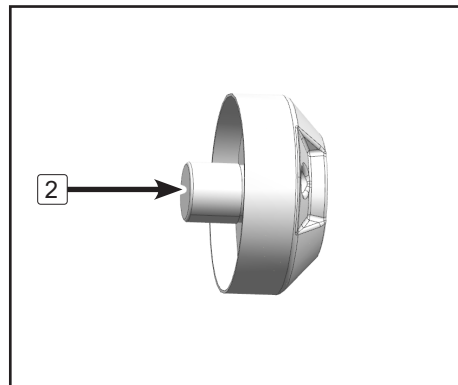
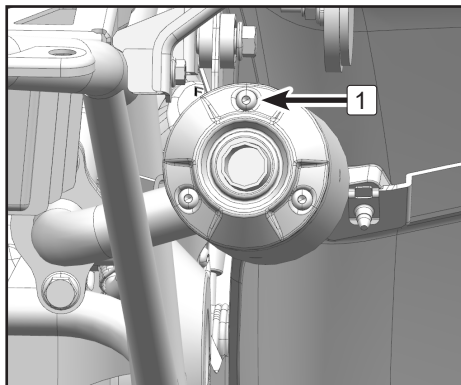

MAINTENANCE & LUBRICATION

Braking System

Brake Fluid Inspection

Front brake fluid reservoir is located at the left handlebar.

Inspect if brake fluid level is between the upper and lower marks through the indicator window 1.

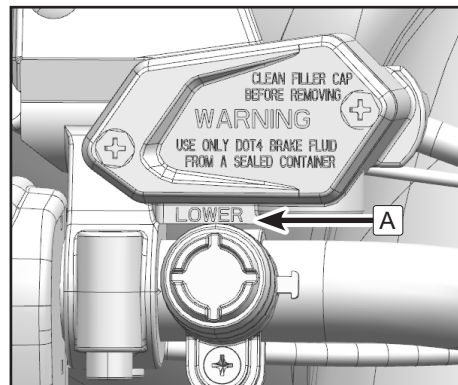
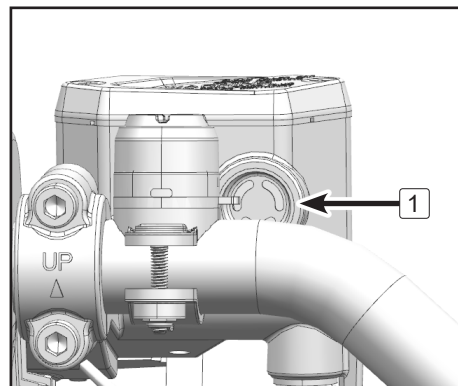

MAINTENANCE & LUBRICATION

Brake Pad Inspection

Front brake lever free play **a** : Please contact your dealer for inspection.

⚠ DANGER

After servicing:

- Make sure the brakes operate smoothly and the lever free play is correct.
- Make sure the brakes do not drag and the brake operation is not spongy.
- All air is emitted from the brake system. Maintenance of brake components requires professional knowledge. These procedures should be performed by your dealer.

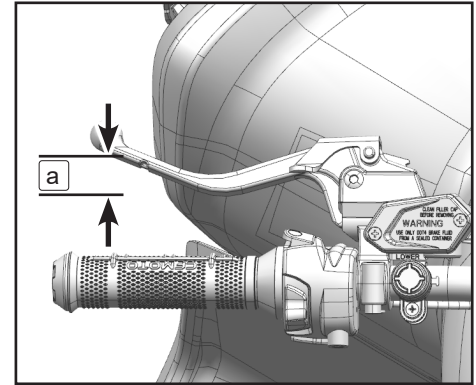

MAINTENANCE & LUBRICATION

Brake Pad Inspection

Check the brake pads **1** for damage and wear.

If the pad thickness **A** is less than .059 in. (1.5 mm) or the disc thickness **B** is less than .118 in. (3.0 mm), have your dealer replace them. Replacement of brake components requires professional knowledge. These procedures should be performed by your dealer.

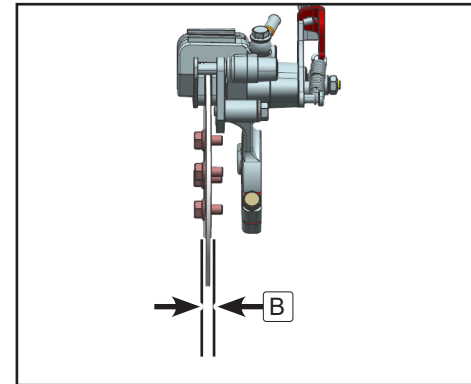
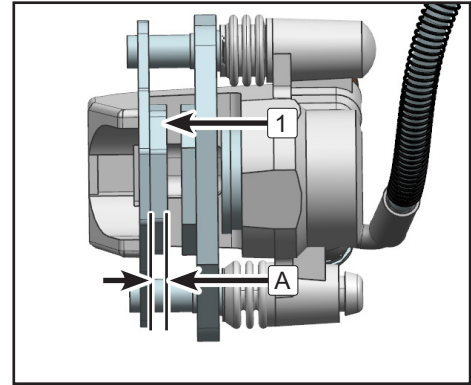

MAINTENANCE & LUBRICATION

Brake Fluid Change

Complete fluid replacement should be done only by trained maintenance personnel. Have your dealer replace the following components during periodic maintenance or when they are damaged or leaking.

Replace the brake hoses every four years.

Inspect the brake fluid level to see if it is between the upper and lower marks.

Insufficient brake fluid may let air enter the brake system, possibly causing the brakes to become ineffective. Before riding, make sure that the brake fluid is above the lower level and replenish it if necessary. The front brake fluid master cylinder reservoir is located on the left side of the handlebar.

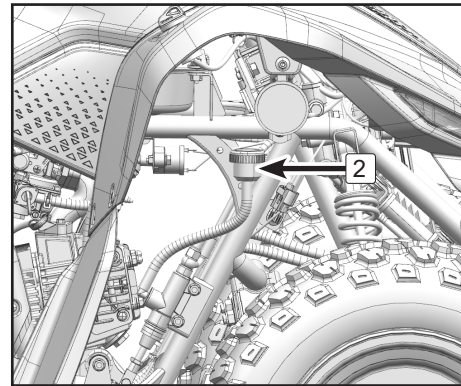
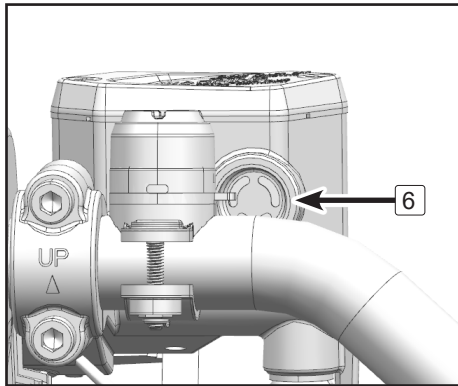

(Available in Select Markets)

MAINTENANCE & LUBRICATION

CAUTION

- When checking the front brake fluid level, make sure the master cylinder reservoir is level by turning the handlebar until the steering is centered and the wheels are forward.
- Use only the designated quality brake fluid. Otherwise, the rubber seals may deteriorate, causing leakage and poor brake performance.
- Recommended brake fluid: DOT4.
- Refill the same type of brake fluid. Mixing fluids may result in a harmful chemical reaction and lead to poor brake performance.
- Be careful that water should not enter the master cylinder reservoir when refilling. Water will significantly lower the boiling point of the fluid and may result in vapor lock.
- Brake fluid may damage painted surfaces or plastic parts. Always clean up spilled fluid immediately.
- Have your dealer check the cause if the brake fluid level goes down quickly or frequently.

MAINTENANCE & LUBRICATION

Foot Brake Pedal Height Adjustment

(Available in Select Markets)

The top of the brake pedal should be positioned 60 mm ~ 70 mm above the top of the footrest. If it is beyond the specification, contact your dealer to adjust it.

⚠ DANGER

Following the requirements:

- Make sure the brakes operate smoothly and that the free play is correct.
- Make sure the brakes do not drag.
- Replacement of brake components requires professional knowledge. These procedures should be performed by your dealer.

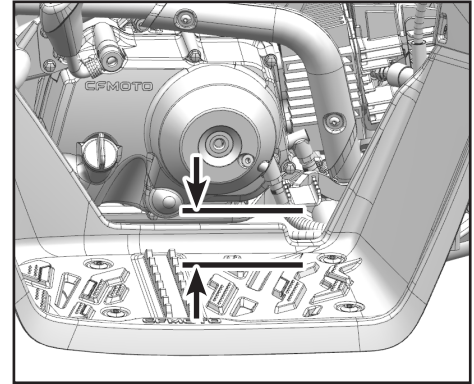

Foot Brake Light Switch

Check the switch assembly or cable to see if they are properly fixed in case of brake light failure. If the brake light still does not work normally, please contact your CFMOTO dealer.

Cable Inspection and Lubrication

⚠ WARNING

Inspect cables frequently and replace if damaged

Lubricate inner cable and cable terminals. If a cable cannot be operated smoothly, contact your dealer for replacement.

MAINTENANCE & LUBRICATION

Wheel and Tires

Removal and Installation

Removal:

- Elevate the vehicle using a jack and support stands.
- Remove four bolts **1**.
- Remove the wheel for replacement.

Installation:

- Install the wheel **A** and the nuts **B**.
- Lower the ATV to make sure the wheels are on the ground.
- Torque the wheel nuts to specification.

Wheel nut torque: 44 ~ 48 ft-lb. (60 N•m ~ 65 N•m).

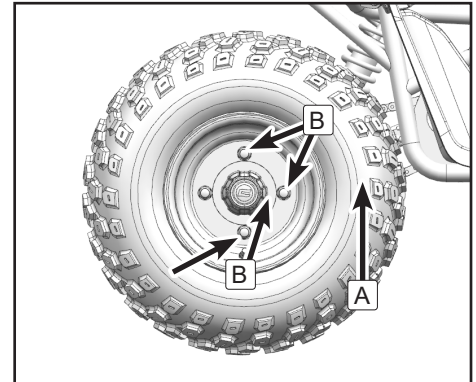
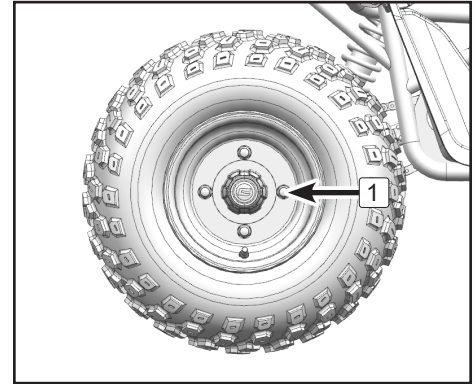

MAINTENANCE & LUBRICATION

Tire Pressure

Inspect the tire pressure before riding:

Tire:

Front tire: AT19×6-10 14F 5.0 psi (35 kPa)

Rear tire: AT18×9-8 26F 5.0 psi (35 kPa)

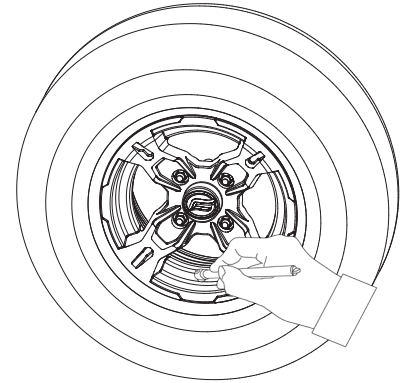

Tread Depth

Inspect the tread depth regularly and replace the tires if the minimum tread depth is less than:

Minimum tread depth: 0.06 in. (1.6 mm)

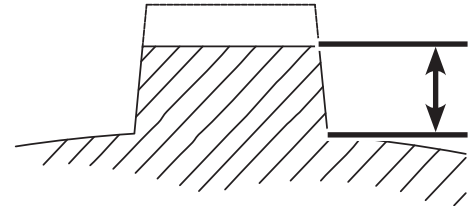

MAINTENANCE & LUBRICATION

Drive Chain Inspection

Drive chain slack and lubrication must be checked daily before riding in accordance with the Periodic Maintenance Chart for safety and preventing excessive wear.

If the chain becomes badly worn or maladjusted, it will make chain too loose or too tight.

If chain is too tight, it will accelerate wear of the chain, sprocket, rear sprocket and rear bearings. Some parts may crack or break when overloaded.

If the chain is too loose, the chain may fall off from the front sprocket or rear sprocket, which may cause locking of rear wheel or motor damage.

The service life of the drive chain largely depends on the maintenance.

Chain Dirt Inspection

Inspect periodically the chain or inspect the chain for dirt after driving in severe conditions.

If the chain is dirty, flush any large dirt particles with a soft jet of water. Clean any residual dirt and lubricant with a proper chain cleaner.

Spray the chain with a proper chain lubricant after the chain is dry.

NOTE

When spraying chain lubricant, do not splash the lubricant onto other parts. Lubricant on the tires will decrease the tire grip, and lubricant on the brake discs will decrease the brake performance. Clean these components with a proper cleaner if over-spray occurs.

MAINTENANCE & LUBRICATION

Chain Tension Inspection

Shift to Neutral gear;

Push up the chain and check its tension;

If the chain tension is out of specification, adjust it to the standard.

Standard value: 0.19 in. ~ 0.59 in. (5 mm ~ 15 mm).

NOTE:

The wear of chain is not always the same. Rotate the rear wheel to repeat the measurement at different positions.

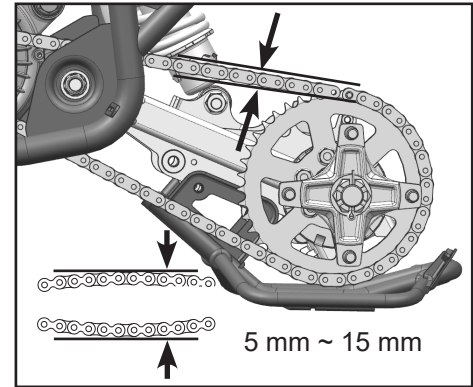

⚠ NOTE

For your safety, please use the original chain suggested by CFMOTO. If the chain is elongated, never cut the chain and reuse it. Have it replaced by an authorized CFMOTO dealer.

Inspect the rear sprocket and motor sprocket teeth for any kind of wear.

If the motor sprocket or rear sprocket is worn or damaged, then replace the whole transmission assembly.



Standard Teeth



Worn Teeth



Damaged Teeth

MAINTENANCE & LUBRICATION

Chain Adjustment(state No.1)

Remove sprocket cover;

Loosen the bolts **1**;

Loosen the bolt **2**;

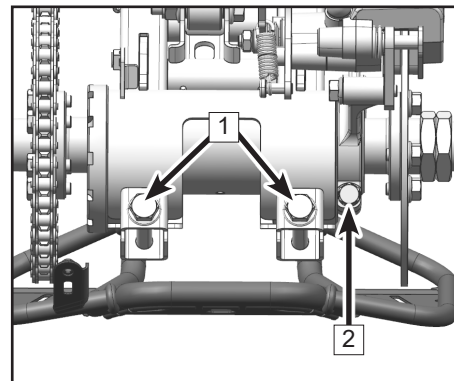

Use a spanner to rotate the axle housing **3** .

Adjust chain tension to the standard range.

Tighten the bolts **2** and **1** .

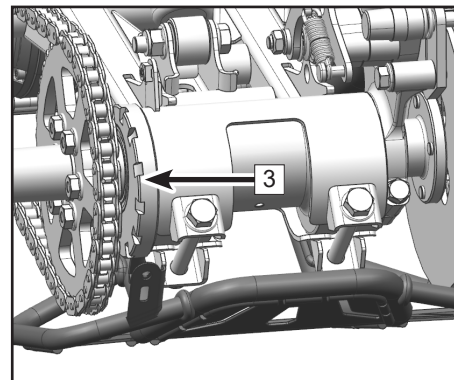

MAINTENANCE & LUBRICATION

Chain Adjustment(state No.2)

Loosen the bolt **1**;

Loosen the bolt and nut **2**;

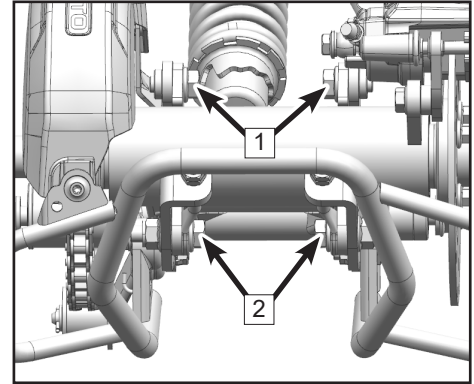

Loose the lock nut **A**;

According to the tightness of chain to adjust the nut **B**;

Re-tighten the lock nut **A**;

Tighten the bolt and nut **1**;

Tighten the bolt and nut **2**.

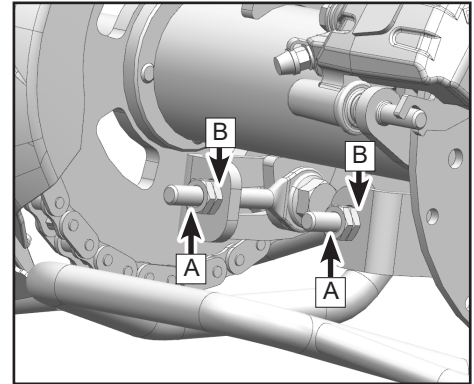

MAINTENANCE & LUBRICATION

Battery

This machine is equipped with a low-maintenance battery 1 which is located under the seat. Therefore, it is not necessary to check the electrolyte or add distilled water in the battery. If the battery seems to have discharged, consult your dealer.

Battery specification: 12V 5Ah.

Battery Use Guidelines:

- Suggested storage temperature: 5~40°C.
- Store it in a cool, dry place with good ventilation.
- Completely recharge the battery before re-installation.
- A special battery charger (constant low voltage/ampere) is required for charging low maintenance batteries. Using a conventional battery charger may shorten the battery life.
- Always make sure the cable connections are correct when reinstalling the battery.

RED: '+' positive.

Black: '-' negative.

Disconnect the RED cable during removal, and reconnect it first during installation.

- Corroded battery connections can be cleaned with a mixture of soda and water.

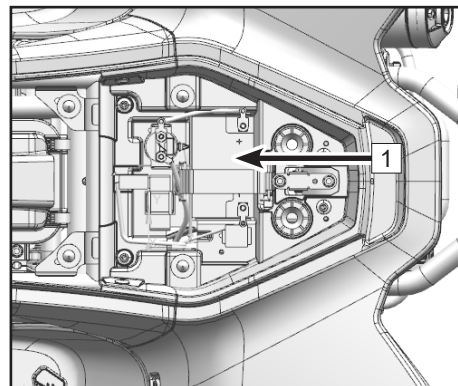

MAINTENANCE & LUBRICATION

Fuse Box

The fuse box **1** is located under the seat.

Relay Box

The relay box **2** is located under the seat.

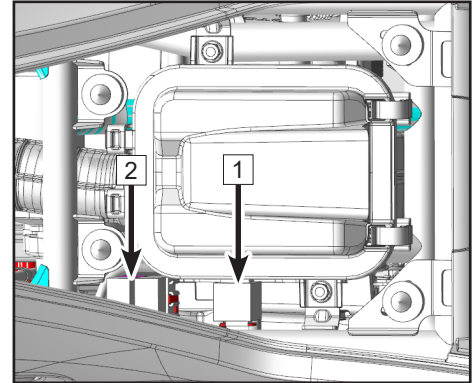

MAINTENANCE & LUBRICATION

Battery Maintenance Guidelines:

- If the vehicle will not be used for a month or longer, remove the battery and store it in a cool, dry place with good ventilation.
- A special battery charger (constant low voltage/ampere) is required for charging low maintenance batteries. Using a conventional battery charger may shorten the battery life.
- Always make sure the cable connections are correct when reinstalling the battery.
RED: '+' positive.
Black: '-' negative.
Disconnect the RED cable during removal, and reconnect it first during installation.
- Corroded battery connections can be cleaned with a mixture of soda and water.

 WARNING
--

Do not try to remove the sealing caps of the battery cells, or you will damage the battery.

 DANGER

Avoid contact with skin, eyes or clothing. Always protect eyes when working near batteries. Keep battery out of reach of children.
--

Emergency Measures

EXTERNAL: Flush the affected area with water. INTERNAL: Seek medical treatment immediately.

EYES: Flush eyes with water for 15 minutes and seek medical treatment immediately. Keep batteries away from sparks, flames, cigarettes or other sources of ignition. Ventilate when charged or used in a closed space.

MAINTENANCE & LUBRICATION

Lights

(Available in Select Markets)

Position Light bulb replacement

Position Light bulb replacement

Both position light **1** and taillight **2** assembly are LED lights, which cannot be repaired if damaged or failed.

Please have your dealer replace the entire assembly when the LED light is damaged or failed.

Position light adjustment

Position light is not adjustable.

Tail / Brake Light Replacement:

Tail/brake light bulb is LED, so it cannot be replaced separately. Please have your dealer replace the entire assembly when the LED light is damaged or failed.

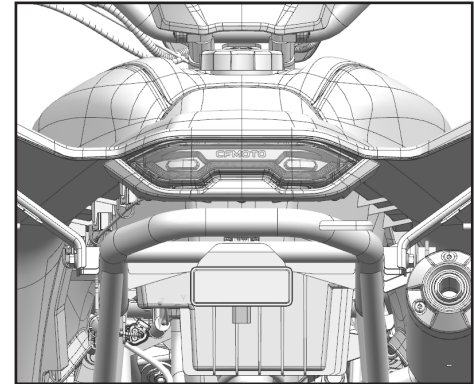
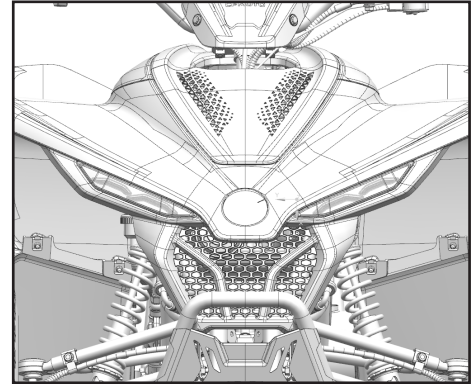

MAINTENANCE & LUBRICATION

Front and Rear Shock Absorber

Standard Shock Absorber

The spring preload can be adjusted to suit the rider's weight and riding conditions.

Adjust the spring preload as follows:

To decrease the spring preload by turning the adjusting ring **2** in direction **A** .

To increase the spring preload by turning the adjusting ring **2** in direction **B** .

⚠ NOTE

A special spanner wrench (if not supplied in tool kit, please contact your dealer.) is used to make this adjustment.

Standard preload position: Position #3

A- Minimum (soft).

B- Maximum (hard).

⚠ NOTE

Always adjust shock absorbers to be the same setting for both left and right sides.

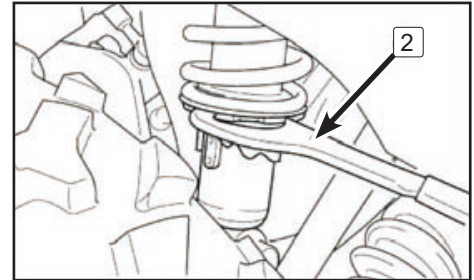
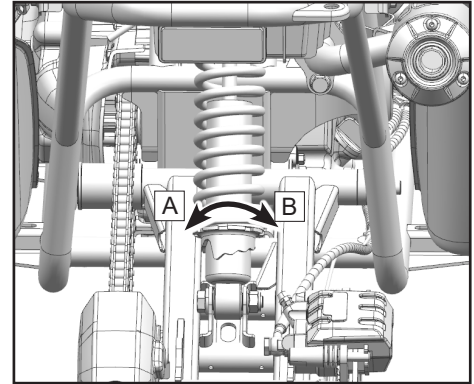

Cleaning & Storage

Cleaning the ATV

Keeping your ATV clean will not only improve its appearance, but it can also extend the life of various components. With a few precautions, your ATV can be cleaned much like an automobile.

 **WARNING**

Before cleaning, batteries should be kept out of reach of children. After cleaning, water should be totally wiped out, and batteries can be used after they are completely dried out.

- Always clean the vehicle after the motor and controls are cooled.
- Avoid applying harsh detergents to seals, brake pads, and tires.
- Wash the vehicle by hand.
- Avoid all harsh chemicals, solvents, detergents, and household cleaning products to clean your vehicle.
- Brake fluid will damage painted plastic surfaces. Wash them off immediately if they splashed on any painted plastics.
- Avoid metal brushes, steel wool, and all other abrasive pads or brushes to clean the vehicle.
- Pay more attention when washing the body panels, headlight covers, and other plastic parts as they can be easily scratched.
- Pay more attention when washing the body panels, headlight covers, and other plastic parts as they can be easily scratched.
- Avoid spraying water into areas such as the battery, charging port and electrical components.

CLEANING & STORAGE

Preparation for Storage

Clean the entire vehicle thoroughly.

NOTE: After cleaning, please check the condition of the whole vehicle to prevent a residue of water.

⚠ DANGER

Oils used on motorcycles are toxic and used oils should be well disposed of. Keep them out of reach of children. And if they are splashed on your skin, please wash them completely.
--

Reduce tire pressure by 20% during storage period.

If the vehicle is stored for over six months, please remove synchronous belts and store them according to regulations.

Spray a corrosion inhibitor on all unpainted metal surfaces to prevent rusting. Avoid spraying it on rubber parts or on the brakes.

Remove the battery. Store it in a cool and dry place.

During storage, the battery must be charged according to Periodic Maintenance Chart to make sure that it has enough power.

Cover the vehicle to prevent dust.

⚠ NOTE

During long storage, power batteries and chains must be stored according to regulations above to make sure that they can be used and are not damaged before next use.

CLEANING & STORAGE

Waxing the ATV

Your ATV can be waxed with any non-abrasive automotive wax. Avoid the use of harsh cleaners since they can scratch the vehicle's surface.

 CAUTION
--

Certain products, including insect repellents and chemicals, will damage plastic surfaces. Use caution when using these products near plastic surfaces.

Storage

Make necessary repairs to your vehicle before storing to prevent further damage when you operate it next time.

In the case of rainy or snowy weather, the vehicle should be stored indoors.

To prevent unsupervised use of the vehicle, remove the battery and keep it out of reach of children.

Check tires

Inspect the tire treads and overall condition. Set the tires to the specified air pressure.

Check fluid levels

Inspect the fluid level and change the fluid if necessary:

- Brake fluid (change it every two years or as required if the fluid looks dark or is contaminated).

CLEANING & STORAGE

Battery Storage

Remove the battery from the vehicle and ensure that it is fully charged before placing it in storage. Protect the battery from freezing temperatures, which can damage the battery.

Lubrication

Inspect all cables and lubricate them with cable lubricant according to instructions. Add all-season grease onto the vehicle's lubricating points.

'Fog' the Engine

- Remove the left cover to inspect the spark plug(s).
- Remove the spark plug(s), rotate the piston to the bottom of its stroke, and pour approximately 2 oz. (15mL ~ 20mL) SAE 10W-40/SG engine oil into the opening.

NOTE

Be careful! If you miss the spark plug hole, oil will drain out from the spark plug cavity, and an oil leak may occur. To access the spark plug hole, use a section of a clean hose and a small plastic squeeze bottle filled with a measured amount of oil.

- Reinstall the spark plug(s). Torque the spark plug to specifications.
- Turn engine over several times slowly. Oil will be forced into and around the piston, and piston rings and the cylinder will be coated with a protective film of fresh oil.
- Reinstall the spark plug(s), cap(s), and the side panel.

NOTE

Starting the engine during the storage period will disturb the protective film created by fogging. Corrosion could occur. Never start the engine during the storage period.

CLEANING & STORAGE

Storage Area and Covering

Reduce tire pressure to be specified and support the vehicle. Make sure the storage area is well ventilated and cover the vehicle with a ATV cover.

In the case of rainy or snowy weather, the vehicle should be stored indoors.

NOTE

Do not use plastic or coated materials. They do not allow enough ventilation to prevent condensation, and may lead to corrosion and oxidation.

Transporting the Vehicle

Follow these procedures when transporting the vehicle:

- Turn off the engine and remove the key to prevent it from losing during transportation.
- Ensure the fuel cap is installed correctly and safely.
- Ensure the seat is installed correctly and safely.
- Block the front and rear wheels to prevent the vehicle from moving.
- Secure both the front and rear of the vehicle frame to prevent the vehicle from rocking or moving.

VEHICLE DIAGNOSIS

VEHICLE DIAGNOSIS

This section is intended to guide an average owner to know some simple items that could cause operating problems. Diagnosis of vehicle issues may require the experience of a technician. Please contact your dealer if a solution is not efficient.

Engine Does not Turn Over

Possible Cause	Solution
Blown fuse	Remount or replace the fuse.
Low battery voltage	Recharge battery to 12.8 Vdc – Make sure the battery is in good condition.
Loose battery connections	Check all connections and tighten them if necessary.
Loose starter system electrical connections	Check all connections and tighten them if necessary.
Engine stop switch	Check all functions.

Engine Pings or Knocks

Possible Cause	Solution
Poor quality or low octane fuel	Replace it with 95 or higher octane unleaded fuel.
Incorrect ignition timing.	Contact your dealer
Incorrect spark plug gap or heat range	Set spark plug gap to specs or replace plugs

VEHICLE DIAGNOSIS

Engine Stops or Loses Power

Possible Cause	Solution
Overheated engine	Clean the radiator and the outside of core components. Clean engine's surface. Contact your dealer.
Fuel shortage	Use 95 or higher octane unleaded fuel.
Kinked or plugged fuel tank vent line	Inspect and replace. Contact your dealer.
Water in fuel	Replace the fuel with a new one.
Fouled or defective spark plugs	Inspect and clean or replace the spark plug.
Worn or defective spark plug wires	Contact your dealer.
Incorrect spark plug gap or heat range	Set the gap to specs or replace the plug.
Loose ignition connections	Check all connections and tighten them.
Low battery voltage	Recharge battery to 12.8 Vdc. Check the charging system and make sure the battery is in good condition.
Clogged air filter	Inspect and replace if necessary.
Electronic throttle control malfunction	Contact your dealer.
Other mechanical failure	Contact your dealer.

Engine Turns Over, Fails to Start

Possible Cause	Solution
Engine turns over, Fails to start	Refuel.
Clogged fuel filter	Inspect and replace if necessary.
Water in fuel	Replace the fuel with 95 or higher octane unleaded fuel.
Inoperative fuel pump	Inspect pump and fuse; Replace if necessary.
Old or non-recommended fuel	Replace the fuel with 95 or higher octane unleaded fuel.
Fouled or defective spark plugs	Inspect spark plugs, replace if necessary.
No spark in spark plug	Inspect spark plugs, make sure the stop switch is on.
Crankcase filled with water or fuel	Immediately contact your dealer.
Clogged air filter	Inspect and replace if necessary; Replace spark plugs as necessary.
Clogged fuel injector	Contact your dealer.
Low battery voltage	Recharge battery to 12.8 Vdc - Make sure the battery is in good condition.
Mechanical failure	Contact your dealer.

Engine Backfires

Possible Cause	Solution
Weak spark from spark plugs	Inspect and replace spark plugs if necessary
Incorrect spark plug gap or heat range	Set gap to specs or replace plugs
Old or non-recommended fuel	Replace the fuel with 95 or higher octane unleaded fuel.
Incorrectly installed spark plug wires	Contact your dealer.
Incorrect ignition timing	Contact your dealer.
Mechanical failure	Contact your dealer.
Speed limiter malfunction	Contact your dealer.

Engine turns over, Fails to start

Possible Cause	Solution
Fouled or defective spark plugs	Inspect and replace spark plugs if necessary.
Worn or defective spark plug wires	Contact your dealer.
Incorrect spark plug gap or heat range	Set gap to specs or replace plugs.
Loose electrical connections	Check all connections and tighten them.
Water in fuel	Replace the old fuel with a new one.
Low battery voltage	Recharge battery to 12.8 Vdc; Check charging system.
Kinked or plugged fuel tank vent line	Inspect and replace.
Incorrect fuel	Replace the fuel with 95 or higher octane unleaded fuel.
Clogged air filter	Inspect and replace; Replace spark plugs if necessary.
Electronic throttle control malfunction	Contact your dealer.
Other mechanical failure	Contact your dealer.
Thin or Dense fuel mixture	Contact your dealer.
Low or contaminated fuel	Add or change fuel, clean the fuel system.
Low octane fuel	Replace the fuel with 95 or higher octane unleaded fuel.
Clogged fuel filter	Replace filter.
High octane fuel	Replace the fuel with 95 or higher octane unleaded fuel.

ELECTROMAGNETIC COMPATIBILITY STATEMENT

The electrical and electronic systems of this vehicle conform to the performance requirements of UNECE R10, and their construction do not cause excessive electromagnetic interference and are not unduly affected by electromagnetic interference.

This equipment has been tested and found to comply with the limits of UNECE R10. These limits are designed to provide reasonable protection against harmful interference in terms of residential installation. This equipment uses and can generate radiate radio frequency energy and, if not installed and used in accordance with the instructions, may cause harmful interference to radio communications. Electronic fence function uses the LORA radiate radio frequency technique, and 433 MHz belongs to the intentional emission of the electronic fence antenna on the vehicle. However, there is no guarantee that interference will not occur in a particular installation. If this equipment does cause harmful interference to radio or television reception, which can be determined by turning the equipment off or on, the user is encouraged to try to clear the interference by one or more of the following measures:

- Adjust the receiving antenna's direction or location;
- Increase the separation between the equipment and receiver;
- Connect the equipment into an outlet on a circuit different from that to which the receiver is connected;
- Ask a dealer or an experienced radio/TV technician for help.

NOTE: Changes or modifications not approved by the manufacturer may invalidate the user's permission to operate the equipment. This vehicle complies with the rules and specifications in the 15th parts of FCC.

Declaration

Declaration of Drivers exposure to noise level

The undersigned :Lai Min jie ,General Manager

Company name and address of the manufacturer:

ZHEJIANG CFMOTO POWER CO.,LTD.

No.116,Wuzhou Road,Yuhang Economic Development Zone,Hangzhou,311100,

Zhejiang Province P.R.China

Make(trade name of the manufacturer): CFMOTO

Type	Commercial name(s) (if available)	Sound pressure value at rider's ear.
CF110AY10	CFORCE 110	Sound power level(4m):99 dB(A)
CF110AY10	CFORCE 110	Sound pressure level:88 dB(A)

Test method: H.7 of EN 15997:2011/AC:2012

Declaration of Vibration declaration

For model CFORCE 110

The vibration of hand - bar: 2.55 m/s^2

The vibration of seat : 1.28 m/s^2 .

Test method: ANNEX I of EN 15997:2011/AC:2012

ZHEJIANG CFMOTO POWER CO., LTD.

EC DECLARATION OF CONFORMITY

Company name and address of manufacturer:

ZHEJIANG CFMOTO POWER CO., LTD.

No.116, Wuzhou Road, Yuhang Economic Development Zone, Hangzhou, 311100,
Zhejiang Province P.R.China

Name and address of the person authorised to compile the technical file:

Powersports Consulting & Trade KG

Alpenstraße14 Top 1, 5020 Salzburg, Austria

Make (trade name of the manufacturer):	CFMOTO
Generic denomination	All terrain vehicles
Type:	Y10
Function	Driving (recreational and/or utility use)
Model	CF110AY10
Commercial name	CFORCE 110
Vehicle identification number:	LCELBHL24N6000042

Conforms in all respects to described in EU Directive 2006/42/EC .

Relevant standards upon which conformity is declared include BS EN 15997:2011 and EN15997:2001/
AC:2012.

Hangzhou P.R.China

DD, MM, YYYY

(place)

(date)

(signature)



Lai Minjie, General Manager

ZHEJIANG CFMOTO POWER CO., LTD.

MANUFACTURED BY:

Add:NO.116,Wuzhou Road, Yuhang Economic Development
Zone, Hangzhou 311100, Zhejiang Province, China
Tel:86-571-86258863 Fax:+86-571-89265788
E-mail:service@cfmoto.com.cn <http://global.cfmoto.com>

DISTRIBUTED BY:

CFMOTO POWERSPORTS INC.
3555 Holly Lane N. Suite #30, Plymouth MN, 55447, USA
Toll free: (888) 8-CFMOTO (823-6686)
Tel: (1) 763-398-2690 Fax: (1) 763-398-2695
www.cfmotousa.com

DISTRIBUTED BY

CANADA MOTOR IMPORT INC.
24 rue Industrielle, Saint-Benoît Labre,
Québec, Canada, G0M 1P0
Tel:418-227-2077
www.cfmoto.ca